

Rutgers University School of Engineering | Department of Electrical and Computer Engineering | 2021



M. Wu



S. Jha

AI for Trustworthy UAVs [page 15](#)
 Community-based Testbed [page 17](#)
 ACM Gordon Bell Prize [page 17](#)
 DARPA Director's Award [page 19](#)
 Sensor Measures Cortisol [page 21](#)
 Cybersecurity Arms Race [page 22](#)
 Defending Voice Assistants [page 24](#)



7X24 Exchange Team

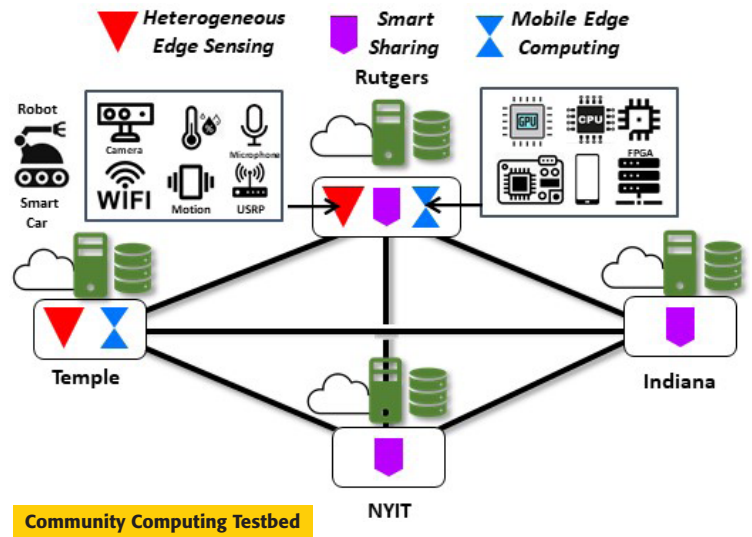

WINLAB Summer Internship Program

Trustworthy Autonomous UAVs via Compiler-Accelerated Efficient AI

[T1] Controller Software Vulnerability Assessment and DNN Construction for Online UAV Security Protection

[T2] Real-time DNN Optimization via Compression and Acceleration

AI for Trustworthy UAVs

Optimized DNN-Based Security Module for Real-Time Attack Detection and Response

Original UAV Controller Software with Hard Real-Time Constraints

UAV's Resource Limited Embedded Processor

Ground Control Station Sensors (IMU, etc.) Actuators (motors, etc.)

contents

Message from the Chair	3
ECE Faculty	4
Student News	6
Meet an ECE Student	8
ECE News	10
Faculty News	18
Alumni News	27
Thank You	27
Advisory Board	28



ECE News is an annual publication of Rutgers ECE.

Editors: Dario Pompili, Narayan Mandayam

Assistants: Pamela Heinold, John Scafidi, Elisa Servito, Jennifer Shane, Michael Sherman

Photography: James De Salvo, Bill Cardoni Photography, Roy Groething, Don Hamerman, Nick Romanenko, J Somers Photography LLC

Design: Bart Solenthaler

ECE News is also available at www.ece.rutgers.edu or can be received by mail by sending a request to ece-help@soe.rutgers.edu

Visit us at www.ece.rutgers.edu



message from the chair



N. Mandayam

ECE Numbers

34

Faculty

4

Part-Time
Lecturers

898

Undergraduate
Students

220

Graduate
Students

119

PhD Students

New Research Grants:

\$15,235,000

Space:

40,000

square feet

Just like the previous year, this continues to be a challenging and yet rewarding year as Chair. While our faculty and staff innovated and improvised to offer our students a remote and virtual pedagogical experience last year, be it for instructional classroom lectures or hands-on laboratory exercises, the new challenge this year as we begin steps toward returning to a pre-COVID setting was operating in a hybrid mode in both virtual and in-person settings. Our students have showed remarkable resiliency in adapting to this new mode of instruction and interaction. Professor **Shantenu Jha**, who has been at the frontlines of the fight on COVID-19 along with other ECE faculty, was part of a team that was recognized with the 2020 ACM Gordon Bell Special Prize for High Performance Computing-Based COVID-19 Research.

Our faculty and students continue to make ECE one of the most vibrant departments at Rutgers, creating a community that fosters excellence in education and research. This excellence is reflected in the remarkable successes and outstanding achievements of our students and faculty members alike. Highlights include Professor **Chung-Tse Michael Wu** (DARPA Director's Research Fellowship), Professor **Hana Godrich** (Engineering Governing Council Professor of the Year), and Professor **Dario Pompili** (IEEE Fellow). Distinguished Professor **Athina Petropulu** and her former student **Bo Li** received the M. Barry Carlton Best Paper Award from the IEEE Aerospace and Electronic Systems Society. Professor **Yingying Chen** and WINLAB Chief Technologist **Ivan Seskar** are leading a NSF funded effort to build a nation-wide community-based mobile edge sensing and computing testbed. Professor **Kristin Dana** was the recipient of a IARPA (Intelligence Advanced Research Projects Activity) award to study wide area terrestrial change using satellite imagery. Professor **Anand Sarwate** was the recipient of a National Institutes of Health (NIH) award for enabling decentralized analysis of neuroimaging data to study and treat drug abuse. Professor **Mehdi Javanmard's** design of a COVID breathalyzer test was featured in the popular press. Like the year before, this year too was marked with a large number of external grants with the department's external research expenditures increasing by 30% over the last two years.

ECE Ph.D. students **Ayman Younis** and **Brian Qi**, working with Professor **Pompili**, won the Best Paper Award at the 2021 IEEE/IFIP Wireless On-demand Network systems and Services Conference. ECE Ph.D. student **Vahideh Vakil** working with Professor **Wade Trappe** won the second-place award for her poster "Dose Optimization for Drug-resistant Cancer Treatment" at the 2021 Applied BioMath Quantitative Systems Pharmacology Summit. An ECE team of seniors **Swetha Angara**, **Ariela Chomski**, **Brooke Getter**, **Neha Nelson**, and **Param Patel** won a \$2,500 prize at the 7x24 Exchange Metro New York 2021 Virtual University Challenge as part of their capstone design project. Another team of seniors **Nathaniel Glikman**, **Alexander Laemmle**, **Nicholas Meegan**, **Bhargav Singaraju**, and **Sukhjit Singh** won the IEEE Power and Energy Society (PES) best poster award at PES Day Global 2021 event. ECE alumnus **Bo Li** (PhD 2017) also received the IEEE Signal Processing Society Young Author Best Paper Award for his work with Professors **Petropulu** and **Trappe**. ECE undergraduate women continue to be trailblazers: **Samantha Cheng** was the Senior Class speaker at the School of Engineering commencement and **Justine Caitli** was elected President of the IEEE Chapter (the fourth consecutive woman president elected!).

Consistent with this excellence, ECE student enrollment remains the highest in the School of Engineering, with our undergraduate enrollment in the sophomore year increasing to 366 students, an approximately 75% increase from 2 years ago. In keeping with the national trend in the US, our graduate student enrollment in the Master's program is down due to the pandemic and travel restrictions. Our students upon graduation, continue to be highly sought after by employers from a broad spectrum of industry, with the fundamentals that students are exposed to here making them versatile and productive employees from day one. This was a great year for our alumni, whose amazing success is a source of inspiration to our students and faculty. Our department has produced outstanding scholars, industry leaders, entrepreneurs. You can meet some of them on page 29-30.

In our pursuit of excellence, the support of our alumni and friends is essential. I would like to thank everybody who supported us this past year. Through this support we were able to supplement startup packages of new faculty, provide student fellowships, fund student attendance at virtual conferences, and maintain state-of-art laboratories.

I am very proud of the accomplishments highlighted in this newsletter. We are currently on campus in hybrid mode and hope to be fully back sometime in the near future. At that time, if your travels bring you to our area, I hope you can visit us to experience up close the vibrancy of this department.

Sincerely,

Narayan Mandayam
Distinguished Professor and Chair

ecefaculty

Waheed U. Bajwa

Associate Professor

NSF Career Award, ARO YIP Award

Research Interests: statistical signal processing, high-dimensional statistics, machine learning, and networked systems.

Grigore Burdea

Professor Emeritus

NSF Initiation Award

IEEE Virtual Reality Career Award

Research Interests: Virtual rehabilitation, telerehabilitation, haptics virtual reality.

Yingying (Jennifer) Chen

Professor and Graduate Director

IEEE Fellow, Peter D Cherasia Endowed

Faculty Scholar, NSF Career Award

Google Faculty Research Award

NJ Inventors Hall of Fame Innovator Award

Research Interests: Smart healthcare, internet of things (IoT), smart safety systems, cyber security and privacy, applied machine learning, hardware-software co-design.

Kristin Dana

Professor

NSF Career Award

Research Interests: Computer vision, robotics, pattern recognition, machine learning, convex optimization, novel cameras, camera networks, computer graphics, computational photography, illumination modeling.

Salim El Rouayheb

Associate Professor

NSF Career Award, Google Faculty

Research Award

Research Interests: Information Theory, Distributed Storage Systems and Networks, Distributed Coded Data, Data Secrecy and Wireless Networks.

Zoran Gajic

Professor

Research Interests: Power control of wireless networks.

Hana Godrich

Associate Teaching Professor

Research Interests: Distributed power systems, energy resources management and storage, energy efficiency, statistical and array signal processing, resource allocation optimization, distributed detection and estimation with application to smart grid, microgrids, and active sensor networks.

Marco Gruteser

Visiting Professor at WINLAB

Peter D. Cherasia Faculty Scholar

NSF Career Award

ACM Distinguished Scientist

Research Interests: Location-aware systems, pervasive computing systems, privacy and security, mobile networking, sensor networks and performance evaluation.

Umer Hassan

Assistant Professor

Research Interests: Biosensing, point of contact medicine, microfluidics, global health.

Mehdi Javanmard

Associate Professor

NSF Career Award, DARPA Young

Faculty Award

Research Interests: Nanobiotechnology, BioMEMS, Point of care diagnostics, Biomarker detection, Microfluidics, Electrokinetics, Applications of nanotechnology to medicine and biology.

Shantenu Jha

Professor

NSF Career Award, ACM Gordon Bell

Special Prize for High Performance

Computing COVID-19 Research

Research Interests: High-performance and distributed computing, computational and data-intensive science and engineering, large-scale cyberinfrastructure for science & engineering.

Yao Liu

Assistant Professor

NSF Career Award

Research Interests: Immersive streaming, mobile/cloud and edge computing, and distributed systems.

Yicheng Lu

Distinguished Professor

NSF Initiation Award,

Rutgers Monroe Faculty Scholar, Faculty of the Year Award (2019)

Research Interests: Micro- and nano-electronics multifunctional oxides - based devices.

Richard Mammone

Professor Emeritus

National Academy of Inventors

Research Interests: Communications pattern recognition, neural networks, signal processing, technology commercialization, processes involved with the innovation of new technology.

Narayan Mandayam

Distinguished Professor &

Department Chair

Peter D. Cherasia Faculty Scholar and Associate Director of WINLAB, IEEE Fellow, Distinguished Lecturer of IEEE

Research Interests: Cognitive radio networks and spectrum policy radio resource management for smart city, privacy in IoT.

Ivan Marsic

Professor

Research Interests: Mobile computing, software engineering, computer networks.

Sigrid McAfee

Associate Professor Emeritus

Research Interests: Defects in semiconductors, nanotechnology, financial engineering.

John McGarvey

Assistant Teaching Professor

Research Interests: Design and simulation of power electronic systems, control system modeling via both the classic and modern state-space techniques, and the design and testing of motor control systems.

Sophocles Orfanidis

Associate Professor

Research Interests: Statistical and adaptive signal processing, Audio signal processing, Electromagnetic waves and antennas.

Peter Meer

Distinguished Professor Emeritus

IEEE Fellow, AMiner Most Influential Scholar

Research Interests: Statistical approaches to computer vision.

Laleh Najafizadeh

Associate Professor

Research Interests: Functional brain imaging, brain connectivity, diffuse optical brain imaging, electroencephalography, cognitive rehabilitation, circuit design and microelectronics, ultra-low-power circuits for biomedical applications, data converters, system on chip, wireless IC design.

Jorge Ortiz

Assistant Professor

Research Interests: Machine Learning for cyber-physical systems, Intelligent infrastructure systems, smart health applications

Athina Petropulu

Distinguished Professor

IEEE Fellow, NSF Presidential Faculty Fellow, Distinguished Lecturer of IEEE

Research Interests: Statistical signal processing, blind source separation, cooperative protocols for wireless networks, physical layer security, MIMO radar, compressive sensing.

Dario Pompili

Associate Professor

IEEE Fellow, ACM Distinguished Scientist, Rutgers-NB Chancellor's Scholar, NSF Career Award, ONR Young Investigator Award, DARPA Young Faculty Award

Research Interests: Wireless networking, underwater communication, mobile edge computing, Internet of Things, autonomy.

Lawrence Rabiner

Distinguished Professor Emeritus

IEEE Fellow, National Academy of Engineering, National Academy of Sciences, IEEE Kilby Medal, IEEE Piore Award, IEEE Millennium Medal

Research Interests: Digital signal processing, digital signal processing, speech recognition, speech analysis, speaker recognition, and multimedia.

Dipankar Raychaudhuri

Distinguished Professor & Director of WINLAB

IEEE Fellow

Research Interests: Future network architectures and protocols, wireless systems and technology, dynamic spectrum access and cognitive radio, experimental prototyping and network research testbeds.

Peddapullaiah Sannuti

Professor Emeritus

IEEE Fellow

Research Interests: Simultaneous internal and external stabilization of linear time-invariant systems in the presence of constraints.

Anand D. Sarwate

Associate Professor

NSF Career Award, A. Walter Tyson Award, Rutgers Board of Trustees Research Fellowship for Scholarly Excellence

Research Interests: Machine learning, distributed systems and optimization with a focus on privacy and statistical methods.

Sumati Sehajpal

Assistant Teaching Professor

Research Interests: Electrical circuit theory and analysis, Class E and Class G RF power amplifiers, modern state-space based approach used to both model and analyze electronic circuits.

Deborah Silver

Professor & Executive Director PSM Program

Research Interests: Scientific visualization, computer graphics.

Emina Soljanin

Professor

IEEE Fellow and Distinguished Lecturer

Research Interests: Efficient, reliable, and secure storage and transmission networks, coding, information, and queuing theory.

Predrag Spasojevic

Associate Professor

Research Interests: Communication and information theory, signal processing and representation, cellular and wireless Lan systems, adhoc and sensor networks.

Maria Striki

Assistant Teaching Professor

Research Interests: Analysis/design/optimization of data algorithms, statistical analysis, mathematical modeling, big data, data analytics, social networks, information systems, cybernetics, wireless-mobile-ad-hoc-cellular networks, (secure) routing, mobile computing, network-computer security.

Matteo Turilli

Assistant Research Professor

Research Interests: Parallel and distributed Computing, software design for distributed infrastructures, computer science computer ethics.

Wade Trappe

Associate Dean for Academic Programs, Professor & Associate Director of WINLAB

IEEE Fellow

Research Interests: Multimedia security, wireless security, wireless networking and cryptography.

Sheng Wei

Assistant Professor

NSF Career Award

Research Interests: Hardware and system security, Multimedia systems.

Chung-Tse (Michael) Wu

Assistant Professor

NSF Career Award, DARPA Young Faculty Award, DARPA Director's Fellowship Award

Research Interests: Microwave and millimeter wave components and circuits, passive and active antennas and arrays, electromagnetic metamaterials, wireless sensors and RF systems.

Roy Yates

Distinguished Professor, Undergraduate Director & Associate Director of WINLAB

IEEE Fellow

Research Interests: Resource management in wireless systems, dynamic spectrum access and spectrum regulation, information theory for wireless networks and future internet architectures.

Bo Yuan

Assistant Professor

Research Interests: Algorithm and hardware co-design, machine learning, signal processing systems, embedded and IoT systems.

Yuqian Zhang

Assistant Professor

Research Interests: Computer vision, machine learning, signal processing.

Jian Zhao

Professor Emeritus

IEEE Fellow, NSF Initiation Award

Research Interests: Silicon Carbide (SiC) semiconductor devices, SiC JFETs, BJTs, MOSFETs, GTOs, high efficiency smart power integrated circuits, SiC sensors, UV and EUV detectors, SiC inverters/converters.

Saman Zonouz

Associate Professor

NSF Presidential Early Career Award

Research Interests: Networks security and privacy, trustworthy cyber-physical critical infrastructures, embedded systems, operating system security, intrusion detection and forensics analysis, and software reverse engineering.

Michael Caggiano

Professor Emeritus

Expertise: Electrical Packaging, microwave packaging, analog circuit design, digital circuit design, digital circuit and logic design.

Richard Frenkiel

Part-time Lecturer

National Medal of Technology, Alexander Graham Bell Medal, National Academy of Engineering, National Academy of Inventors, Draper Prize

Expertise: Cellular Systems, Wireless Networks.

Phil Southard

Part-time Lecturer

L3Harris Technologies

Expertise: Field programmable gate arrays (FPGA's), computer hardware, digital design, programmable logic, application specific integrated circuits.

studentnews

Senior Spotlight Amber Haynes ENG'21

by Amy Wagner



Amber Haynes ENG'21, from Newark, NJ, entered the School of Engineering through the Educational Opportunity Fund (EOF) program in 2017 and earned a bachelor's degree in electrical and computer engineering with a minor in mathematics. During her time at Rutgers, she conducted machine learning and data science IoT research with electrical and computer engineering assistant professor **Jorge Ortiz** in his Cyber-Physical Intelligence Lab and co-authored a paper that was accepted to an international conference. She also participated in the Minority Engineering Educational Task (M.E.E.T.) student organization.

Just before graduating, Amber shared her thoughts and reflections from her time at Rutgers Engineering and as a member of the EOF family.

How SOE/EOF Impacts Success

I had no idea how much I would come to depend on the EOF program and especially my advisor, assistant dean and EOF/EOP director **Michael Brown**. As a first-generation college student living in the projects, I did not realize how sheltered I was from the professional world and I also did not realize at the time how many obstacles I would have to manage just to continue pursuing my degree.

A big change I underwent in my first two years, was learning how to be my best professional

self. Pitching to recruiters, speaking passionately about my interests, interviewing, and even standing my ground and managing conflicts are all things I would not have known how to do if it were not for my EOF advisors. Yet just as I began growing as a student, unexpected turns in my life that caused me to struggle with my academics.

Surmounting Personal Challenges

Though I had always had to balance taking care of my mom, who has several chronic illnesses, with doing my best in school, this especially picked up steam in my sophomore year. My mother suffered from an injury that caused her to be bedridden for seven months straight. We had no resources to help take care of her, so I was tasked with catching the train nearly every day to take care of her while trying to manage my engineering classes and labs.

“With my degree, I have the chance to become economically mobile and garner real change.”

While I love my mom dearly, this was extremely daunting and stretched me very thin. I doubted myself immensely and did not know if I would be able to finish school. I tried to remain strong in front of her, but on the train rides back to New Brunswick I would break down. There was increasing pressure from my classes and professors that year, and if I did not have Dean Brown to lean on, for consolation, mentorship, and advocacy, I would not have been able to continue my college career. He helped me stay motivated to do what I could to catch up in my classes.

By May, I had maintained a 3.4 GPA despite my challenges with my home life. By the start of my junior year, I had won an outstanding research award from Rutgers LSAMP for Computational Neuroscience I had done over the summer and I had already received an offer for an internship in my junior year summer. I had been on the Dean's List numerous times.

I then had to manage the change none of us were expecting late in my junior year: the COVID-19 pandemic. As someone who already suffers from anxiety, especially surrounding the well-being of my mother, I found it difficult to find the energy to continue school once again. I struggled to keep up with classes again.

Despite how much I wanted my degree and loved academia, it was hard to see a light at the end of the tunnel. I came close to not passing certain classes, and if it were not for Dean Brown's encouragement to push through, I would not be graduating this May.

I am graduating with a 3.2 GPA. I am extremely grateful to the SOE-EOF program at Rutgers for keeping me motivated to push for change for my family.

Facing a Bright Future

With my degree, I have the chance to become economically mobile and garner real change. The first thing I am going to do when I start working is move. I want to move out of the apartment my mother and I are in as fast as the money will let me. She deserves so much better.

In the future, I eventually hope to pursue a higher degree in mathematics and/or engineering because research and teaching are interests of mine as well. As for my immediate plans after graduation, I am currently managing a job search that I hope will lead me into the industry as a software engineer. I am eager to see how my ideas can make direct change for the world, in what I hope will be an immensely positive way.

Senior Class Speaker Samantha Cheng ENG'21

by Amy Wagner

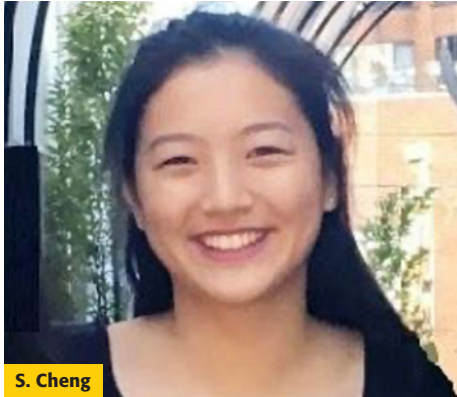

S. Cheng

Electrical and computer engineering (ECE) and English double major **Samantha Cheng** has served as an Engineering Ambassador, the chair of the First Year Integration Peer Mentor Program, and a MATLAB learning assistant. She took part in the Aresty Summer Science program, where she studied the effect of climate change on the Mackenzie River Basin. She also had a software development internship with MITRE, where she worked on several government-related projects, as well as a systems engineering internship with Lockheed Martin. An Honors College Scholar and SoE Class of 2021 convocation speaker, she will be joining Cambridge, Massachusetts-based Akamai Technologies' Platform Rotation Engineering Program after graduation.

Why Rutgers?

I chose it for its perfect balance of having the resources of a large school, while still having smaller, tight-knit communities. The SOE provides a great collaborative community, while the university offers research and career experiences. The different campuses, schools, and people contribute to the diverse experiences I have had here. This semester, I even took a class on Animal Handling, Fitting, and Exhibition on the Cook Farm – and worked with goats.

What drew you to computer engineering?

I'm interested in how hardware and software work together and I liked that the computer engineering track is part of the broader, interdisciplinary ECE department, which means I could obtain experience in both hands-on

lab work involving circuitry as well as coding software. I appreciate the versatility of being able to take ECE skills and knowledge and apply them elsewhere, such as in biomedical or environmental sciences.

What about your English major?

I've always loved reading and analyzing literature, so I knew I wanted to take a few literature classes in college. On my first day of school at Rutgers, I sat in on an English lecture and that class solidified my interest and made me want to study English more formally. Studying English has also improved my communication and critical thinking skills, which are important in any field.

What do you most value about your Rutgers education?

I value the community the most. I've learned so much in my four years here, but I couldn't have done it without the support of my classmates and professors. Rutgers SOE has given me a large network of people – and the people are truly what makes Rutgers SOE unique. As graduation comes closer, I'm comforted by the fact that I have so many people I can rely on or reach out to in the years to come.

“The SOE provides a great collaborative community.”

Did any professors make an impact on you?

Many of my professors have made profound impacts on me as a student and as a person. One in particular is industrial and systems engineering professor Dr. **Elsayed Elsayed**. I took his Introduction to Reliability Engineering class as an elective. I'm so appreciative of the time he took to talk to each student – he is clearly invested in his students' futures. I greatly admire his passion for his work, and hope one day to have a passion and expertise similar to his.

How did the coronavirus pandemic affect you?

The switch to online learning was a challenge, but I adapted with the help of professors and other resources. Many professors were even more accessible through online learning than before, and it was a great help to still be able to schedule meetings and have face time with them.

I was also able to take trainings through the learning assistant program, that helped me both be a better student in my classes and to be a better MATLAB learning assistant. These trainings covered topics such as metacognitive skills, time management, and online resources.

What did it mean to you to be selected as the SOE Class of 2021 speaker?

Being the SOE convocation speaker is an exciting and meaningful experience for me because I want to share a message that can resonate with the whole class. Graduation is a time to look back on the great memories we've made at Rutgers, as well as to look forward to new beginnings. I hope this gives everyone a moment to reflect on their own paths, and celebrate themselves and their achievements.

Do you have any advice for incoming students?

Don't be afraid to ask questions! This is a typical piece of advice, but I was still afraid as an incoming freshman to ask too many questions. It turns out that people – whether they're fellow freshmen, upperclassmen, professors, or anyone else at Rutgers – are more than happy to help you out. There's nothing wrong with asking questions – as long as you ask and listen.

What will your job at Akamai Technologies involve?

I'll be rotating through four tracks – information security, platform engineering, global performance operations, and networks – during Akamai Technologies' two-year Platform Rotation Engineering Program. I'll be taking on different roles depending on the track, so I can gain exposure to these fields before fully committing to one. I'll also be learning general technical and soft skills that I'll be able to apply in any role.

Meet an ECE Student

.....

Justine Catli

Hi! I'm Justine, an ECE senior with a Statistics minor!

Before Rutgers, I chose my major as a part of a project in my junior year of high school. I knew I wanted to work in tech, but I didn't want to be limited to one field. Upon researching more about ECE and the versatility of work, I was so excited to find my path. On top of that, being from Edison, NJ, Rutgers felt like a perfect fit for me between the school, the engineering program, and the myriad of opportunities.

So when I came here, I immediately got involved in Douglass Residential College (DRC), the Society of Women Engineers (SWE), and Rutgers Institute of Electrical and Electronics Engineers (IEEE) as part of the Robotics division. As a freshman, everything was new and inspiring! I got to learn so much from my mentors. They helped me academically and professionally. Because of mentors I had freshman year, I became a MATLAB Learning Assistant, I became the Professional Relations chair of IEEE, and I presented at my first research symposium as a part of Project SUPER!

Project SUPER is a program in DRC designed to prepare women with little to no formal training to go into research labs with various Rutgers professors in their field. Unable to wait until spring semester to be awarded a spot in the program, I talked to Dr. **Hana Godrich**, then ECE undergraduate director. Thanks to her, I went on to shadow ECE senior design capstone team #18, where we won second place! Our project was dedicated to help sight-impaired people navigate city-scapes on foot using arduino distance sensors and an Android app utilizing the Google Maps API for audible walking directions. I'm proud of my design contribution of the fanny pack to the project as it made the product marketable and relatively cheap. Being able to also present a poster at the Project SUPER Symposium that spring was especially fun because I got to see the other women in the program present their research as well.

Capstone was a great experience that helped me feel more comfortable at my next research experience at WINLAB, summer of 2019. There, I got to work on the COSMOS project, helping create a virtual reality testbed for self-driving

cars! It helped flush out my presentation skills for technical-heavy projects. I got to learn C#, Solidworks, and Unity for the first time. This was the second project I got to work on that had social good implications, and being able to do this kind of work early on had a lasting impact on how I thought about products and design.

Going into sophomore year, I had plenty of new responsibilities outside my first real ECE classes. It was my first time being a Learning Assistant (LA) for the MATLAB course, I was responsible for general events, sponsorships, and professional development as the External Vice President of IEEE, and I was doing mentorship programs in SWE and Project SUPER.

Because of my previous experiences and my continued contact with industry professionals, I was able to join Lockheed Martin Sikorsky in Stratford, CT! I was working on a ground-based application that helped pilots track their flight data. Specifically, I helped system integration of legacy craft information onto the existing platform despite differing data representation. The experience really opened my eyes to the working world and what life could be like after graduation. I got the opportunity to network with company leadership and managed my own "Speed Networking" event with the interns, young professionals, and some of the managers. I'm proud of my experience, especially since I was able to extend my internship through Fall 2020.

In Spring 2021, I started my junior year by becoming a Data Structures LA. I also managed IEEE's inaugural Social Good Hackathon! The marriage of my two passions, helping people and tech, culminated in working with various nonprofit organizations such as the Raritan Valley EMS, the Rutgers Learning Centers, and more! It was awesome to have a large community event, especially since we were able to invite alumni because we were all online.

Coming to summer 2021, I was a Software Analysis Engineering Intern at Samsung Electronics America! I was assisting our Networks team enhancing an internal tool by integrating communication with container-based virtualization network functions. Outside of regular work, our program had a "CEO Problem Solver" competition where we were divided into teams to present solutions on current issues affecting Samsung. Our team won the opportunity to present to KS Choi, the President



J. Catli

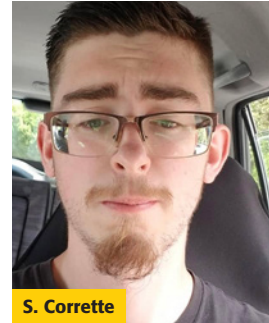

S. Corrette

and CEO of Samsung Electronics North America! It was an amazing experience I'm grateful for, especially since I joined WayUp's Intern 100 as one of the top 100 interns across America in 2021.

Looking forward to senior year, I'm excited to take more elective classes and continue putting my passions to work. I'm also happy to be spearheading IEEE as the new president! After a year and a half of being online, I'm sure my last year at Rutgers is going to be wonderful!

.....

Sabian Corrette

I grew up in Pemberton, NJ moved to Toms River, NJ to finish up middle school and finished high school in Edison, NJ so I have been around the state a little bit. I like to play guitar and bass in my free time or even just chill out and listen to music. I have a black dog named Rennie that I occasionally bring to campus as well.

I am currently a first-year graduate student currently pursuing my Master's degree in Electrical and Computer Engineering. I recently graduated from Rutgers with my Bachelor's of Science in Electrical and Computer Engineering. During my time at Rutgers, I have had the opportunity of being a part of different student organizations such as the Engineering Governing Council (EGC) and Rutgers IEEE during my Sophomore and Junior years. Within IEEE, I was a member of the Robotics division helping out when I could in both Micromouse and VEXU. I also was on the eboard for IEEE as the web developer leading to the website being redone with a newer look and our official Rutgers domain (<https://ieee.rutgers.edu/>). Similarly in EGC, I had the opportunity to be the web developer for the student organization there too. My time in both student organizations allowed me to become more connected with

Meet an ECE Student (continued)

my fellow peers and learn how important being a part of student organization really was.

Throughout my undergraduate studies, I worked as the web developer and web administrator for the School of Engineering under the Director of Technology, Dr. **Alexei Kotelnikov** (Engineering Computing Services, ECS). Dr. Kotelnikov helped immensely in expanding my knowledge in other topics including system administration, managing clusters, and a unique work experience that embraced developing and testing new technology that could be used by the rest of the school. I feel that I have gained a good grasp of how to work well individually and excel in the work environment thanks to working with ECS my four years here and I will continue doing so as a graduate student.

As a graduate student, I am now focusing on Computer Engineering specifically for my Master's degree and currently a TA for Professor **Philip Southard's** Embedded Systems II course. I had the opportunity of meeting Professor Southard last semester while taking his Embedded Systems I course, which quickly became one of my most favorite courses at Rutgers and has led me to pursue embedded systems as a career as well.

Sachin Mathew

I'm currently a senior majoring in Computer Engineering and Computer Science with a minor in Mathematics. I was brought to Rutgers and more specifically the Engineering Honors Academy through Dean Jean Antoine and the Governor's School of Engineering and Technology Program for rising seniors in High School. Since that summer project designing water pump impellers in CAD, I have moved on to more field specific research and likewise towards leading research for students in that same program.

I was able to first engage with ECE research at WINLAB under Professor **Yingying (Jennifer) Chen** and her PhD students. Alongside my fellow ECE students I was able to work on marrying Signal Processing and Machine Learning to detect and analyze the change in Wi-Fi signals upon different user movements for fitness assistant or user authentication purposes. With that background, I was able to move more into model construction and tuning in Machine Learning with Professor **Richard Martin** to build lightweight Neural Networks using a fixed-point

standard rather than floating-point at minimal accuracy loss. These experiences in WINLAB have brought me to the place I am now - conducting ECE Research for the JJ Slade Program under Professor **Wade Trappe**. For this senior research, we are aiming to build a computer model for real-time patient levels for certain conditions such that this model can be used to expedite changes in dosage for those patients given their real-time biosensor data.

If not evidenced by the big block of text surrounding my research, it has been something that I've been passionate about here. In Rutgers Engineering, I was able to discover my passion for exploration within my fields as well as my desire to help others explore those fields themselves. Since returning to GSET as an undergraduate, I've had the opportunity to lead three projects around data science with incredibly talented high school researchers. Throughout all of these, I have been lucky enough to be able to work directly with students and introduce them to aspects of study and application that aren't the most accessible when read or addressed alone. I've been able to see them grow more confident and capable as engineers.

These experiences together have guided my professional ambitions towards hopefully teaching and conducting research in the future as a professor myself. I'm incredibly excited to see where I can go with the skills that the ECE department has given me going forward.

Carolina Naim

I am a Ph.D. candidate at Rutgers University in the Electrical and Computer Engineering (ECE) Department. I am part of the CSI lab, which is under the direction of Prof. **Salim El Rouayheb**. My research interests include privacy and security with applications in distributed computing and machine learning. Before coming to Rutgers in 2017, I received my B.S. in Communication and Computer Engineering from the American University of Science and Technology in Beirut.

The topic of my Ph.D. research was motivated by the fact that privacy has become one of the biggest challenges facing the big data and machine learning revolution, with ethical, societal, and even political implications. An exciting project I worked on considers privacy in Federated Learning, where multiple participants



S. Mathew

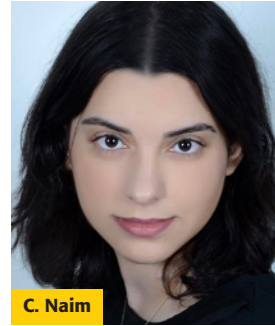

C. Naim

want to contribute their data to a central unit of operation. However, privacy is a significant concern because the data they wish to share can reveal personal and sensitive information about those participants' groups, such as their political views, gender, health condition, or race, to name a few. Therefore, as part of my research, I devised an algorithm that allows the users to contribute their data while providing privacy guarantees to their group. Unfortunately, privacy comes at a premium cost in terms of system overhead, which has motivated another related research project: ON/OFF Privacy. My ON/OFF privacy algorithms enable a user to switch their privacy between ON and OFF. It is based on the principle: "Turn it off when you don't need it" These projects have resulted in the publication of several papers in top conferences and journals like the IEEE International Symposium on Information Theory, the IEEE Information Theory Workshop, the IEEE Transactions on Information Theory, and the IEEE Transactions on Forensics and Security. Moreover, Rutgers awarded me the TA/GA Professional Development Award in 2018 and a Graduate Fellowship in the ECE department in 2019. I also had the opportunity to work as a teaching assistant at Rutgers for courses such as Linear Systems and Signals and Digital Logic Design. And by observing and assisting great teachers, I learned the importance of guiding students to think critically about engineering problems and explore the fundamentals of concepts and theories. I was also a summer instructor for Linear Systems and Signals. In my future career as an educator, I aim to evoke the same excitement of discovery and achievement that I felt both as a student and a teacher at Rutgers. In recognition of my efforts and results as a teaching assistant at Rutgers University, I was awarded the ECE Teaching Assistant Award for Fall 2020. As someone who is a lifelong learner, I wanted to pursue a degree to further my understanding of my field, and Rutgers has equipped me with immeasurable knowledge and expertise that have propelled me forward in my academic journey and career so far.

ecenews

Wade Trappe appointed Associate Dean for Academic Programs



Dean **Thomas N. Farris** announced that Prof. **Wade Trappe** will assume the role of Associate Dean for Academic Programs. Prof. Trappe will fill the position previously held by **Henrik Pederson** who has become the Interim Dean of the School of Graduate Studies.

In undertaking his role as associate dean for academic programs, Dr. Trappe will partner with Dean Farris and senior leadership to advance overarching strategic direction, especially in graduate and international education, and high-level programmatic direction that prioritizes SoE initiatives among academic departments. Dr. Trappe will, additionally, provide leadership, support, and mentoring for the school's assessment and accreditation activities (ABET) and provide oversight of master's student recruitment, education, retention, and outcomes activities.

In working to strengthen organizational effectiveness, Dr. Trappe will forge strong working relationships with programmatic and administrative leaders, including SGS, Rutgers Global, Career Exploration and Success, and the New Brunswick Chancellor-Provost's Office to ensure our academic programs are clearly represented.

Roy Yates appointed as the ECE Undergraduate Director



Prof. **Roy Yates** will serve as the new ECE Undergraduate Director for the period from July 1, 2021 to June 30, 2022.

Asked about his new role, Prof. Yates reports "This is a surprisingly interesting and even gratifying position. I've learned something new about the department almost every day. The students are remarkably appreciative and thankful whenever I can send an email or sign a form to solve their problem."

Prof. Yates has been an outstanding researcher and educator and contributed to the department's success in many roles during his during his 30+ years at Rutgers. Over the last 4 years, he has been instrumental in recruiting several outstanding faculty colleagues to the department as the Chair of the ECE faculty search committee. He currently serves on the Chancellor-Provost's Strategic Diversity Planning committee. He has also served in leadership roles at WINLAB, including as Director and Associate Director.

Emina Soljanin receives NSF US-Israel Binational Science Grant



ECE Professor **Emina Soljanin** is the recipient of a new NSF award for the research project titled "Redundancy for Storage in the Edge." This is a three-year project in partnership with Technion, Israel that is supported under the NSF US-Israel Binational Science Foundation (BSF) Collaborative Research Opportunities. Rutgers' share of the award is \$500,000.

In this project Professor Soljanin will design storage schemes to facilitate emerging Internet of Things (IoT) ecosystems. The IoT revolution is driven by a surge of applications based on intelligent edge devices, such as smart cities and homes, autonomous vehicles, online video gaming, virtual and augmented reality, and machine learning. The back end of these systems is a central service where a large amount of data generated by edge devices is continuously collected, aggregated, and analyzed. Unfortunately, traditional cloud services cannot provide performance guarantees that the latency-critical applications require, mainly due to round-trip times, which can take several hundreds of milliseconds. Thus, such applications will likely rely on edge services—an emerging technology tightly coupled with 5G cellular networks. This project focuses on enabling unstable edge nodes to collectively provide a reliable storage service for unpredictable user demands. Towards this goal, redundant storage schemes for edge systems will be designed and evaluated.

ECE 2021 Capstone Program Highlight

Capstone design program, or engineering design projects, marks an important milestone in our ECE undergraduate students' education. The program offers students with an opportunity for a full-scale project development mimicking industrial environment from ideation, teamwork, budget, and time constraints along with design challenges. This year marked the beginning of a full year capstone program, spanning over fall 2020 semester and spring 2021. This enabled the program to expand the curriculum to include additional professional enrichment activities and increase collaboration with the industry. With this important progression in the program development, it has faced unexpected challenges as COVID-19 constrained required adapting to remote learning. With over 250 students who participated in the program with 57 projects, the students' efforts and outcomes were commendable!

Faculty and industry advisors play a significant factor in supporting students with design and implementation of cutting-edge technology and research. Their efforts are key to the success of our capstone program and the students' learning experience. With the challenges everyone faced in 2021, we are more than ever grateful for the support we got from our industry and academia advisers, **Philip Southard**, **Cameron Greene**, **Dean Telson**, and **Dillion Houghton** from L3Harris, **Shahab Jalalvand** and **Nick Ruiz** from Interactions LLC, **Daniel Arkins** from BlackRock, **Andrew Levine** from Commure, **Hubertus Franke** from IBM, **Donald Bachman** from Siemens, and **Dr. Kevin Lu** from Stevens. These projects were partly industry driven and others were students' ideas cultivated by experience professionals. These collaborations support expands the large spectrum of knowledgebase and expertise available to the students through the capstone program.

Operating under COVID-19 limitation, while introducing more challenges to this program, also introduced new opportunities. In the fall of 2020, we held multiple faculty and industry panels. One panel focused on 'How COVID changed work and career development' with **Anand Bhagwat** from JP Morgan Investment Bank, **Gregory Mueller** from L3Harris and **Shahab Jalalvand** from Interactions LLC. The panelist addressed many of the students concerns and help students understand what they should expect when joining the workforce given the changing environment. Another panel of former alumni, including **Niharika Mishra** (Capital One, BS'19), **Varun Bhandari** (Bank of America, BS'19), **Deepti Upmaka**

(Bank of America, BS'19), **Bhargav Tarpara** (BS'18), **Akanksha Pathak** (Verizon, BS'18), and **Timothy Petersen** (L3Harris, BS'20). These recent alumni shared their experience with capstone and the 'secrets' for a successful project. It was a great opportunity to open a discussion on career planning and other topics of priority to the students. The 7x24 Exchange, Metro New York Chapter board members, **Donald Bachman**, **Brian Schafer**, **Mike Carron**, and **Mary Glynn** introduced the organization and the yearly University Challenge opportunity for students. This competition among the tre- state universities offer an opportunity for one team each year to present their project to a diverse group of professionals. A Scrum Training session has been offered by **Sirish Peddinti**, **Yatti Patel**, and **Mary Kalla** from BlackRock. This training helped students with being more effective project development. Additional workshops included project management, ideation and goal setting the s.m.a.r.t way, lead by Prof. **Hana Godrich**. These sessions, spread throughout the fall semester, accompanied the students organizing into teams, developing project ideas, and getting an adviser. Most of the projects developed under the capstone program at the ECE department are students driven.

While the year of 2020 and 2021 introduced new constraint it also generated innovation in both project topics and in projects prototype development. This year's projects have a strong focus on covid related needs. In "QuickShift" project (by **Swetha Angara**, **Ariela Chomski**, **Bracha 'Brooke' Getter**, **Neha Nelson** and **Param Patel**, advised by **Andrew Levine** from Commure and Prof. Hana Godrich) the students created a user-friendly web interface using Commure's React Components that enable practitioner to log into their account remotely and update their schedule with ease. "Tracking Cleaning Progress with Computer Vision" project (by **Andrew Ko**, **Edler Olanday**, **Parth Patel**, and **Piotr Zakrevski**, advised by Prof. **Yuqian Zhang**) focused on the use of computer vision to keep track of surface cleaning. In another project, "Mask and Temperature Recognition System (MATRS)" (**Ansh Gambhir**, **Rishi Shah**, **Anurva Saste**, **Srinivasniranjan Nukala**, and **Kyle Tran**, advised by Prof. **Umer Hassan**) students developed a testing station that will automate the verification of mask wear and temperature measurements.

Technologies in the service of communities were developed in the "SMART Glove" project (by **Erik Castro**, **Brian Cheng**, **Nicholas Chu**, **Gary Qian**, and **Thomas Lu**, advised by Prof.

Hana Godrich) who built a glove and web app that offers a fun way to learn sign language, making it an accessible, self-learning, tool. The "Mental Health Chatbot: KANA" project (by **Jennifer Huang**, **Samuel Zahner**, **Nishad Nalgundwar**, and **Vincent Chan**, advised by Prof. **Kristin Dana**) was designed to help individuals locate resources for their unique situation through an emotionally aware virtual dialogue system.

Sustainability was in mind for the team who developed smart solutions such as "Improvements to the Viability of Solar Panels in the Field" (by **Nathaniel Glikman**, **Alexander Laemme**, **Nicholas Meegan**, **Bhargav Singaraju**, **Sukhjot Singh**, advised by Prof. **Michael Caggiano** and **Cameron Greene** (L3Harris) and "Eagle-View: Realtime Onboard Monitoring in Agriculture for Weed Clusters" (by **Andrew Dass**, **Andrew Vincent**, **Virajbhai Patel**, **Harsh Desai**, **Jeffrey Samson**, advised by Prof. **Dario Pompili** and **Khizar Anjum**).

The climax of the program is Capstone Expo Day. This year, the expo was moved to the virtual world by transforming it into a virtual conference-like experience. In this event students' hard work, creativity, skills and knowledge were evaluated by a panel of industry and academia judges.

This year's panel of judges included over 40 representatives from the industry. The virtual event enabled us to include professionals from around the country, among them many recent alumni.

The panel chose the top 10 ranking projects and additional three awards: Best in Innovation, Best in Research, and Best in Impact. The following judges participated this year: **Donald Levy** (AT&T), **Richard Huber** (AT&T), **Kamal Abburi** (Microsoft), **Govindaraj Muthukrishnan** (Morgan Stanley, '17), **Harry Li** (MIT Lincoln Laboratory '18), **Jonathan Ksiezopolski** (KAMTech Solutions, B'16), **Anand Bhagwat** (JP Morgan 91/94), **Marc Campos** (JP Morgan), **Mareesh Kumar Issar** (Hughes Network Systems, '20), **Parneet Kaur** (Sea Machines Robotics, '17), **Tim Petersen** (L3Harris, '20), **Matthew Torcivia** (Naval Nuclear Laboratory), **Umama Ahmed**, L3Harris ('19), **Kshitij Minhas**, SRI International ('16), **Shahab Jalalvand**, Interactions LLC, **Nazmul Islam**, Qualcomm ('14)

ECE 2021 Capstone Program Highlight (continued)

Hubertus Franke, IBM
 Sarah Hallac, Blackrock
 Akanksha Pathak, Verizon ('18)
 Luke Miller, SpaceX ('18)
 Revan Sopher, Headway ('16)
 Sakshi Sardar, Capital Path Institute ('19)
 Rajiv Jain, CDW ('94)
 Cat Le, Duke University ('16)
 Mhammed Alhayek, Bloomberg ('18)
 Stephen Wilkus, Spectrum Financial Partners
 Mike Dolan, L3Harris ('99)
 Don Bachman, Siemens ('86,'08)
 Daniel Arkins, Blackrock
 Ed Cordero, Protiviti
 Neharika Bhandari, NBCUniversal (B'18)
 Parsa Hosseini, Tesla ('18)
 Pengfei Sun, F5 Networks ('19)
 Deepti Upmaka, Bank of America ('19)
 Syed Naqvi, Consolidated Edison ('17)
 Varun Bhandari, Bank of America ('19)
 Niharika Mishra, Capital One ('19)
 Akash Patel, Nordic Semiconductor ASA ('15)
 Roshni Shah, American Express ('20)
 Nirali Shah, Apple Inc ('17)
 Karen Raihofer, Summit Recycling Advisory Committee
 Diksha Prakash, Schrödinger Inc. ('20)
 Parth Parikh, Amazon ('17)
 Akash Nayak, Fidelity Investments ('20, '21)
 Mark Koenig, Bridgewater-Raritan School District
 Jagadeesh Dantuluri, Keysight Technologies

Their expertise, care, and insights were priceless in making the hard decisions as for the top projects. Our judges were very impressed with the quality of the projects and commended our students' capabilities and enthusiasm.

The Capstone Expo event and students' awards were sponsored by Siemens, Harris, 7x24 Exchange Metro New York Chapter, JP Morgan Chase, Blackrock, and Interactions.

We would like to thank our faculty, advisers, judges, staff, and sponsors for their commitment to this program and for making the capstone experience for our class of 2021 professionally effective and memorable.

This year's top ten awards winners are:

FIRST PLACE

(awarded \$100/student, sponsored by BlackRock)

Project S21-34: SMART Glove

Team members: Erik Castro, Brian Cheng, Nicholas Chu, Gary Qian, Thomas Luy

Advisor: Dr. Hana Godrich

SECOND PLACE

(awarded \$75/student, sponsored by 7x24 Exchange Metro NY)

Project S21-10: Improvements to the Viability of Solar Panels in the Field

Team members: Nathaniel Glikman, Alexander Laemmle, Nicholas Meegan, Bhargav Singaraju, Sukhjit Singh

Advisors: Dr. Michael Caggiano and Cameron Greene (L3Harris)

THIRD PLACE

(awarded \$50/student, sponsored by L3Harris)

Project S21-49: Mental Health Chatbot: KANA

Team members: Jennifer Huang, Samuel Zahner, Nishad Nalgundwar, and Vincent Chan

Advisor: Dr. Kristin Dana

FOURTH PLACE (\$25/student)

Project S21-13: Eagle-View: Realtime Onboard Monitoring in Agriculture for Weed Clusters

Team members: Andrew Dass, Andrew Vincent, Virajbhai Patel, Harsh Desai, Jeffrey Samson

Advisors: Dr. Dario Pompili and Khizar Anjum

FIFTH PLACE (\$25/student)

Project S21-45: RU-Therapy

Team members: Khizer Humayun, Akash Govindaraju, Sianna Arruda, Rebekah Bediako, Hedaya Walter, and Katherine Moreira

Advisor: Dr. Hana Godrich

SIXTH PLACE (\$25/student)

Project S21-11: Project LOUIS

Team members: Sahil Patel, Darshan Singh, Luan Tran, Tan Ngo, and Khanh Nguyen

Advisor: Dr. Kristin Dana

SEVENTH PLACE (\$25/student)

Project S21-38: F-SCAN DS: Foot Splinter, Cut, and Nick Detection System for the Purpose of Preventing Amputations in Diabetics

Team members: Amber Haynes and Maria Rios

Advisors: Dr. Jorge Ortiz

EIGHTH PLACE (\$25/student)

Project S21-02: Real-time Analytics of Hurricane Gliders

Team members: Radhe Bangad, Matthew Chan, Brian DelRocini, Kinjal Patel, Jasmine Philip

Advisor: Dr. Scott Glenn

NINTH PLACE (\$25/student)

Project S21-21: Tracking Cleaning Progress with Computer Vision

Team members: Andrew Ko, Edler Olanday, Parth Patel, Piotr Zakrevski

Advisor: Dr. Yuqian Zhang

TENTH PLACE (\$25/student)

Project S21-20: CO2NSUME

Team members: Samantha Moy, Shreya Patel, Atmika Ponnusamy, and Nandita Shenoy

Advisors: Dr. Jorge Ortiz

Capstone Special Award Winners

BEST IN RESEARCH AWARD (\$50/student)

Project S21-49: Mental Health Chatbot: KANA

Team members: Jennifer Huang, Samuel Zahner, Nishad Nalgundwar, and Vincent Chan

Advisor: Dr. Kristin Dana

BEST IN IMPACT AWARD

(awarded \$50/student)

Project S21-38: F-SCAN DS: Foot Splinter, Cut, and Nick Detection System for the Purpose of Preventing Amputations in Diabetics

Team members: Amber Haynes and Maria Rios

Advisor: Dr. Jorge Ortiz

BEST IN COMMERCIALIZATION

(\$50/student) a tie between two teams

Project S21-31: Occupancy Monitoring System with Computer Vision Algorithms

Team members: Samantha Cheng, Kylie Chow, Sonia Hua, Sneha Shah

Advisor: Dr. Yuqian Zhang

Project S21-31: I. O. Clean

Team members: Jonathan Banks, Edward Gaskin, Alex Martorano

Advisor: Dr. Kevin Lu (Stevens) and Dr. Hana Godrich

Congratulations to class of 2021 for an exceptional capstone year!

A full list of projects is available on the ECE site under <http://www.ece.rutgers.edu/>

2021 WINLAB Summer Internship Program



The 2021 WINLAB Summer internship program ended on August 6th with a virtual open house held over Zoom. This was the second internship to be held during the coronavirus outbreak but unlike last year's internship program, some of the interns were able to visit the lab to work on their projects in person by the end of the internship. Thanks in large part to Rutgers' diligence with testing and vaccination, WINLAB was able to safely open its doors in early July so that Rutgers students could collaborate in person and work with equipment at the lab. Fifty-three students participated in the program over the summer; three graduate students, thirty-five undergraduate students and fourteen high-school students. The 2021 program had fourteen different projects ranging in topic from entropy simulation to 5G spectrum measurement to machine learning-based bee tracking.

The bee-tracking project is one part of an ongoing research project at WINLAB to test whether bees are sensitive to electromagnetic fields. For this project, supervised by Dr. **Rich Martin** and Dr. **Rich Howard**, the students used videos from an observation hive to develop video processing algorithms that would be able to detect bee locations and orientations in the video frame. Other students

worked on developing a "bee-simulator", which would be able to simulate bee movement based on predictive models created from the videos. **Justin Yu**, who has been a WINLAB intern since high school, said this: "The WINLAB internship is always an amazing experience and I've learned so much more via my hands-on work than I have in my college classes. I've worked on the Bee Project since 2019 and the experience I have gained in these short few years is invaluable and I am grateful to have discovered the project through WINLAB."

Several other groups contributed to ongoing projects at WINLAB; the self-driving and smart intersection projects have been worked on for several years, with the work this summer focusing on extending the simulated environment and models from last summer. Students learned to program in python and use the robotics software ROS in the simulated environment, with the goal of mirroring the physical setup at WINLAB. Although many of the students worked on the project by using the WINLAB infrastructure remotely, by the end of the summer several students were able to come to the lab in person and work with a robot in person, allowing them to use ROS on a real piece of hardware.

Professor **Yingying Chen** noted that: "The WINLAB internship gives both undergraduate and high school students great opportunities to be involved in our research work. The student group worked with my PhD students on the WiFi sensing project to perform user authentication in the summer 2021. We met with the students regularly and discussed different kinds of problems they encountered during their learning in both hardware and software. We had a great time working with the 4 undergraduate and 2 high school students in the group." One of the students working on the project was **Aditi Satish**, who said that "As a graduate student, one of the main reasons I chose Rutgers as the university to pursue my masters was WINLAB, a one-of-a-kind research laboratory pioneering in research. This summer I worked in WINLAB as a summer intern and the experience was great! I got to know a lot of people and worked on an amazing project. ... It was a great learning experience for me."

While there were several projects focusing on traditional subjects at WINLAB—5G signal measurement, spectrum sensing, etc.—some of the projects were a little more unusual. Professor Martin also supervised a project in which the students used python to write simulations

of Maxwell's demon in order to quantify the conversion rate using Shannon's definition of information. The students also added errors to the information to quantify how the conversion degrades with information loss.

Deep learning was a common theme in many of the projects—a project supervised by Professor **Bo Yuan** focused on machine learning on FPGAs, giving undergraduate and high school students an opportunity to run state of the art machine learning algorithms in a novel environment. Another project focused on the low-level implementation of neural networks by investigating how to perform the training phase of machine learning using fixed point integer arithmetic. The students successfully ported the MNIST machine learning example, which performs handwritten digit recognition, to use integer arithmetic rather than floating point, while maintaining the same accuracy. The code and results were posted to Github.

Another trend in projects was pandemic safety measures: Professor **Jorge Ortiz** supervised a project that measured prevalence of social distancing measures using dashcam and traffic camera videos. The interns working on this project had an opportunity to make contributions to an active research project with real world data, which is a valuable experience for undergraduate students. Another project focused on masks: "I worked on the Real-Time Machine Learning on the Embedded Devices Project, where we designed a program for facial recognition as well as mask detection. Through this internship I was able to learn subjects that I hadn't learned in my core curriculum at the time, such as a new coding language. It also made me more interested in machine learning, so I am looking towards taking electives related to it, something I wouldn't have considered before the internship. The internship also had a lot of flexibility, so I was able to focus both on the internship as well as my summer classes. Overall, it was a very low pressure and high rewarding experience. I was able to come out of the program knowing more than when I went in!" said Rutgers student **Nelusha Dias**.

Despite the successful conclusion of another remote summer internship, we are looking forward to having the next round fully in person, hopefully including our international colleagues from Engineering Polytech Angers' as in the years past", said WINLAB chief technologist **Ivan Seskar**. "We already started planning to have a crowded lab in the summer of 2022 with a number of exciting hands-on projects".

Enabling Low Latency in High Uncertainty Environments

by Emina Soljanin

The IoT revolution is driven by a surge of applications, such as smart cities and homes, autonomous vehicles, online video gaming, virtual and augmented reality, and remote surgery. These applications mostly operate under high uncertainty but require low latency that traditional systems cannot provide. Edge cloud is an emerging technology tightly coupled with 5G. It is supposed to provide 1-5ms latency between the user device and the cellular tower. Transferring storage and computing capabilities to the edge nodes improves user-perceived application performance.

Edge and other distributed computing systems rely on their storage layers to provide data access services for executing applications. Thus, a computing system's overall performance depends on the underlying storage system's data access performance. Data access times are the main efficiency bottleneck in large-scale (cloud) systems. Many factors can cause slowdowns, but they primarily occur because of the contention in storage access resource sharing by multiple workloads. Poor or variable performance can happen at any volume of access requests, but it is aggravated at overloaded storage nodes. Therefore, it is paramount to provision and design storage systems that can distribute and balance data requests across the storage nodes for stable and fast service.

Modern storage systems replicate data across nodes, thus increasing access-service resources. An object can be stored at an adequate replication level if its request rate is known. However, the popularity of an object is not only unknown but it also fluctuates. Replication is even less suitable for edge nodes whose storage and I/O capacities are restricted. User mobility and geo-locality increase the dynamic range of data access patterns. While edge caches can handle skews in popularity by selectively increasing the number of replicas of popular objects, such quick adaptation may not be possible in the data-center setting, especially for large data objects that are used in data analytics or machine learning applications. Our research focuses on designing storage systems that will handle (significant) skews and changes in data objects' popularity at low storage and capacity costs.

Interestingly, the best storage schemes often combine replication and coding. To see that, consider the system in Fig. 1, consisting of two

cameras monitoring two intersecting streets. One camera acquires content a concerning the traffic on one of the streets, and the other, content b , concerning the other street. We can store files a and b redundantly on four nodes.

The figure shows three redundant storage schemes: replication, coding, and combined replication and coding. Given that each node can serve $\mu = 1$ requests per second, we want to characterize (λ_a, λ_b) , the rates of requests for a and b that the system can support. We call the set of the supported demands the service rate region.

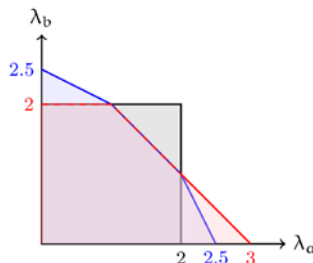
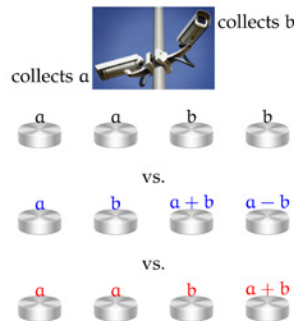

Combined replication and coding (hybrid) supports asymmetries in demands (λ_a, λ_b) better than coding or replication alone. This capability is essential when the interests in traffic a vs. traffic b change, e.g., depending on the time of the day. Hybrid schemes often maximize the service rate region.

Our research postulates that the service rate region should be an essential consideration in designing efficient distributed storage that must provide low latency for time-sensitive applications and remain stable under high uncertainty. These two projects address the mathematical and the systems aspects of designing data storage schemes under service rate region considerations.

ECE Capstone Team Awarded 7x24 Exchange Metro New York 2021 Virtual University Challenge Grant

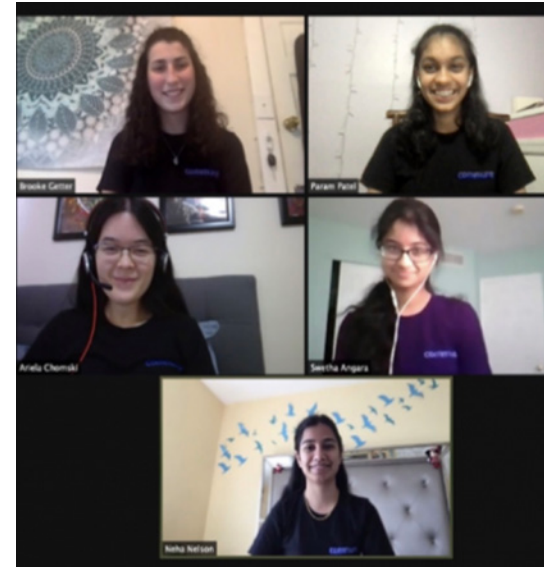

A shout out to our 'QuickShift' capstone team, **Swetha Angara, Ariela Chomski, Bracha 'Brooke' Getter, Neha Nelson, and Param Patel**, who represented the ECE department at the 7x24 Exchange Metro NY 2021 University Challenge for their creativity, impact, and excellent work. You made us all very proud!

Swetha Angara, Ariela Chomski, Bracha 'Brooke' Getter, Neha Nelson, and Param Patel are all senior year undergraduate students who developed 'QuickShift' for their capstone design project. The industry adviser is Andrew Levine from Commure and the faculty advisor is Dr. **Hana Godrich**. The team was awarded a \$2,500 grant for the project. The ECE capstone program was awarded \$4,000 to further invest in senior year capstone projects and research related to datacenters.

Their project addresses the need for an effective scheduling system for hospitals and practitioners that will provide access to critical information in a timely manner. The project objectives were to create a user-friendly web interface using Commure's React Components and create a robust back end using Commure's FHIR-based APIs and OptaPlanner's scheduling algorithm. snapshot

The 7X24 Exchange is a leading knowledge exchange organization in the mission-critical facilities space for those who design, build, operate, and own data centers. The 7X24 Exchange Metro New York

ECE Researchers receive NSF Supplement Grant to develop Trustworthy Autonomous UAVs via Compiler-Accelerated Efficient AI

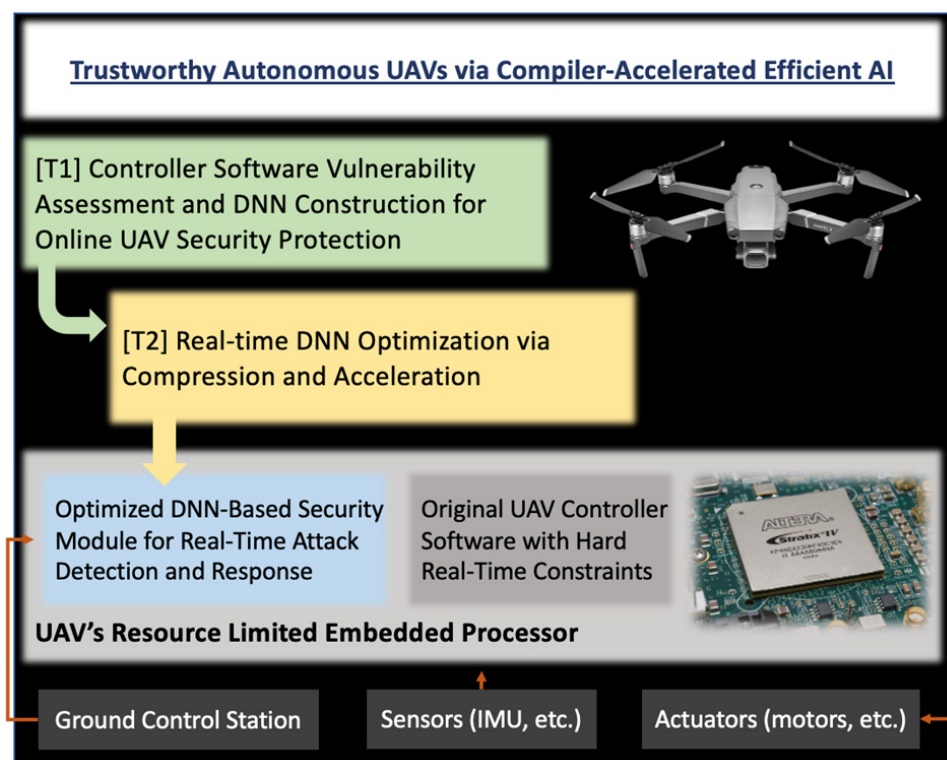

A team of Rutgers ECE researchers led by Associate Professor **Dario Pompili** (PI) along with co-PIs **Saman Zonouz** (Associate Professor) and **Bo Yuan** (Assistant Professor) are the recipients of a \$280K supplement award from the National Science Foundation under the DARPA-NSF Real-Time Machine Learning (RTML) program for the project titled "Trustworthy Autonomous UAVs via Compiler-Accelerated Efficient AI," in collaboration with the University of Washington (UW).

The ECE team will optimize their developed Deep Neural Network (DNN)-based Unmanned Aerial Vehicle (UAV) controller security solutions (via firmware reverse engineering and symbolic execution) that include real-time intrusion detection and response capabilities. This project will enable trustworthy UAV flight operations despite complex security attacks

via optimized distributed deployment of data-driven AI-based intrusion resilience on UAVs resource-limited processors. The technical challenges addressed in the project include: (1) Accurate and optimal security monitoring and decision making for flight-time attack detection and response; and (2) Resource-optimization and DNN acceleration for execution of security solutions side-by-side along with the drone's main controller software stack. Success will be measured via full flight demonstration of security-enhanced UAV controllers against various attack types, e.g., Denial of Service (DoS), false data injection, and vulnerability exploitation. As part of this DARPA-NSF collaborative program, the team will deliver the first working solution and open research directions for use of real-time efficient AI for security protection of cyber-physical safety-critical platforms even beyond UAVs.

New Faculty Member Yao Liu

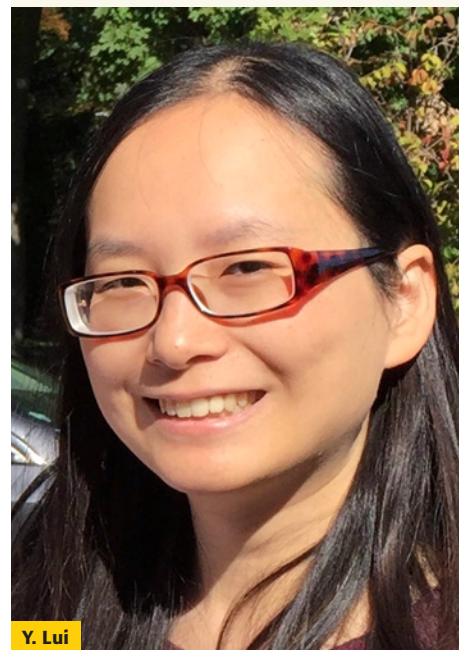

Y. Liu

Dr. **Yao Liu** joined Rutgers ECE as an assistant professor in Fall 2021. Before that, she was an associate professor in the Department of Computer Science at Binghamton University, State University of New York. Her research interests include immersive streaming, mobile/cloud and edge computing, and distributed systems. She has received the NSF CAREER Award, Binghamton University's Watson School Recognition Award for Early-Stage Distinguished Research, George Mason University's Volgenau School Outstanding Graduate Award, the Best Student Paper Award at ACM Multimedia Systems Conference (MMSys) in 2017, and the Best Paper Award at MMSys 2020. She received her PhD degree from George Mason University and her BSc degree from Nanjing University.

Cyber-physical Security for Industrial Control Systems

by Saman Zonouz

Overview. Cyber-physical Industrial control Systems (ICS) are used in a multitude of control systems across several applications of industrial sectors and critical infrastructures, including electric power transmission and distribution, oil and natural gas production, refinery operations, water treatment systems, wastewater collection systems, as well as pipeline transport systems. ICS typically consist of interconnected embedded systems, called programmable logic controllers (PLCs). In a distributed ICS, multiple PLCs jointly control a physical process or the physical environment. Using a series of sensors and actuators, PLCs can monitor the physical system's state and control the system behavior. This makes the correct functioning of PLCs crucial for the correct and safe operation of these systems.

Problem. This critical role of the PLCs makes them a valuable target for adversaries aiming to interfere with any of these systems. Past incidences show that such attacks are applied in practice, often remaining undetected over a long period of time. Examples include the infamous Stuxnet worm against Iranian nuclear uranium enrichment facilities as well as the BlackEnergy crimeware against the Ukrainian train railway and electricity power industries. These attacks demonstrate impressively that targeted attacks on critical infrastructure can evade traditional cybersecurity detection and cause catastrophic failures with substantive impact. The discoveries of Duqu and Havex show that such attacks are not isolated cases as they infected ICS in more than eight countries. Nation-state ICS malware has typically either targeted the control programs of PLCs or the central control infrastructure (e.g., operator workstations). However, academic research has demonstrated even more sophisticated attacks against ICS and PLCs that can circumvent existing defense mechanisms by manipulating the PLC's firmware and incorporating physics-aware models into the attack code.

Attack vectors. A comprehensive defense against ICS attacks needs to protect against various attack vectors. (1) The software determining a PLC's behavior could be replaced by a malicious program. Updating the PLC control program over the network is an intended functionality of PLCs to allow central management. However, the control program can also be manipulated if an attacker gains physical access to a PLC. (2) The PLC firmware (which includes the OS) could be manipulated/replaced either via the network or through physical access. (3) The attack can exploit a

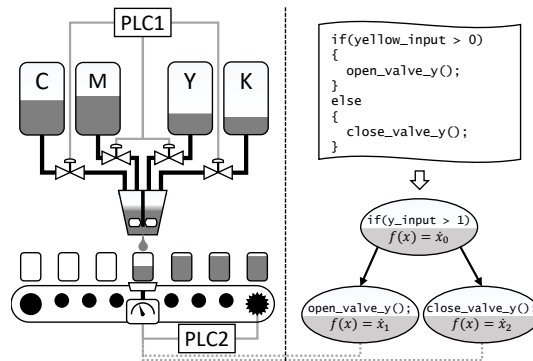

SCADMAN system overview and architecture. The central control (SCADA) is extended with a component called SCADMAN-MONITOR that monitors the behavior of the distributed ICS and can detect compromised controllers in the system

memory corruption vulnerability (e.g., buffer overflow) in the PLC's control programs and/or firmware for code-injection or to launch run-time attacks such as return-oriented programming (ROP), to manipulate a PLC's behavior. (4) Memory corruption vulnerabilities can be exploited to launch data-only attacks against a PLC to manipulate its behavior. For instance, the initiation of a trigger-response may be inhibited by manipulating the associated control parameters, e.g., a threshold value that determines whether the action must be started. For all above enumerated attack vectors, a common goal of the adversary is to modify the physical behavior of the system. As long as the attacked device behaves correctly the overall system will continue to operate correctly. Therefore, the ultimate goal of the attacker will always be to change a device's behavior.

Defenses. Our work in defending against the above-mentioned ICS attacks can be generally categorized into two categories: defenses that focus on verifying the integrity of the software running on a PLC and defenses that verify the behavior of the overall ICS based on models that abstract control decisions of the PLC software. In the former case, PLC-based control logic verification solutions (e.g., our NDSS'2014 paper that uses symbolic execution and model checking) typically cannot account for attacks which replace and/or modify the underlying firmware below the control logic programs. Similarly, solutions that enforce compliance via state estimation or cyber-physical access control from within the PLC could be circumvented as well. Our prior work, Zeus (CCS'2017), uses side-channel analysis to verify the software control flow of programs running on a PLC, but cannot defend against firmware modifications nor sensor data attacks. By extension, offline, static analysis of control programs being loaded onto PLCs provides even less run-time guarantees. For ICS-based verification techniques, it has been shown that state estimation can be

used to infer the control commands issued by distributed controllers or to detect false data injection attacks based on the sensor data. Such protection mechanisms may be circumvented via physics-aware attacks (e.g., demonstrated by our NDSS'2017 paper). Further, supervised machine learning has been used to characterize physical invariants of the CPS. However, such approaches depend on the training data to include all corner cases of the system execution and are not based on the control flow of the software.

We recently presented the first Control Behavior Integrity (CBI) solution for distributed industrial control systems. Unlike previous state estimation approaches, our solution does not abstract the behavior of the cyber-components (i.e., PLCs). Instead, the solution precisely simulates the state of all PLCs. By monitoring the input and output behavior of the entire ICS, our solution can detect inconsistencies within the actions of PLCs. To enable a global view of the entire ICS, a consolidated control program of all PLCs in the system is generated to resolve functional dependencies between individual programs. The consolidated control program in conjunction with a physical state estimator is used to determine a set of acceptable states at any particular point in time. For that, we need means to analyze which control-flow paths are valid given the current system state. Based on this context-aware control-flow path analysis, our solution determines benign resulting states. Comparing the set of benign states against the reported sensor readings and actuation commands from the ICS allows our solution to detect anomalies in the system behavior. This makes our work agnostic to the various attack technique listed above, that can be used to cause a PLC to deviate from its intended behavior and makes the solution a powerful tool to protect ICS against a wide range of attack vectors.

WINLAB Team receives NSF Grant for Developing Community-based Mobile Edge Sensing and Computing Testbeds

A team of researchers led by Professor **Yingying Chen** (PI) and WINLAB Chief Technologist **Ivan Seskar** (Co-PI) at WINLAB have received an NSF award for the project titled "Nation-wide Community-based Mobile Edge Sensing and Computing Testbeds." This three-year \$1.5M project is collaborating with three other universities including Indiana University, Temple University, and New York Institute of Technology.



Y. Chen

I. Seskar

What is being studied, what is the scope of the research?

The advancement of mobile sensing devices and mobile computing technologies have triggered new research opportunities in mobile edge sensing and computing, including human activity recognition, wellbeing monitoring, user authentication, human dynamics tracking, etc. However, research in mobile edge sensing and computing suffers from labor-intensive training, unrealistic experimental environments, heavy environmental interferences in practical scenarios. In addition, different research groups usually conduct small-scale experiments separately, which makes it difficult to share the research results and data among groups in the same community. This research project will design and develop an experimental infrastructure to share data/models nationwide and perform practical and repeatable experiments that can benefit many research groups in edge sensing and computing community.

What will be designed and developed for community usage?

The goal of this project is to build a large-scale, mobile edge sensing and computing infrastructure that can provide practical experimental environments, rich user tools and services, and data/model sharing to a broad research community. The proposed

research infrastructure includes three organically connected functionalities to provide repeatable experimental environments, facilitate data/model-sharing, and connect separated research groups on a national scale. The three functionalities include: 1) the mobile sensing functionality for supporting compelling research in low-effort large-scale sensing data collection, robot-enabled experimenting, and privacy-preserved learning on mobile edge devices; 2) the edge computing functionality integrating remote-operated mobile edge devices and mobile development kits to support research in software and hardware co-design and on-device AI learning for low-cost mobile devices; and 3) the novel data and model sharing functionality that supports a broad spectrum of mobile edge sensing and computing research areas. Furthermore, a uniform web portal will be developed to allow users to use these functionalities remotely. The community-based infrastructure will provide an essential hardware and software foundation that enables cutting-edge research in computer and information sciences, including mobile edge sensing, hardware and software co-design, and distributed computing with sharable large-scale data from practical environments. The outcome from this project, including the unique integrated functionalities, powerful tools and services, and comprehensive datasets, will further enhance the research collaboration of many research groups in academia, industry, and government across the nation.

What are the potential impacts on research going forward?

By utilizing this new infrastructure, individual research groups can be connected to conduct large-scale research with low efforts. Many interdisciplinary communities can also be brought together, researching via the proposed infrastructure, including deep learning-based hardware design, smart healthcare, AR/VR, human flow monitoring, smart home, and smart city. The research results can benefit interdisciplinary curriculums with new research topics and tasks for undergraduate/graduate and minority students.

What are the outreach activities to institutions and community?

Besides conducting the research described above, the team plans to build a robust user community via seminars, workshops, tutorials, and invited talks. The team will hold seminars and workshops to develop and nurture a diverse user community from students, researchers, and engineers in mobile edge sensing and computing. The results of the proposed infrastructure will be demonstrated to the conference participants and industrial partners. The team will also provide summer intern opportunities and develop teaching modules for incorporation into high-school and undergraduate student outreach activities. In addition, the research topics of mobile edge sensing and computing and the proposed functionalities and tools will be integrated into the interdisciplinary curricula at Rutgers and other participating institutes.

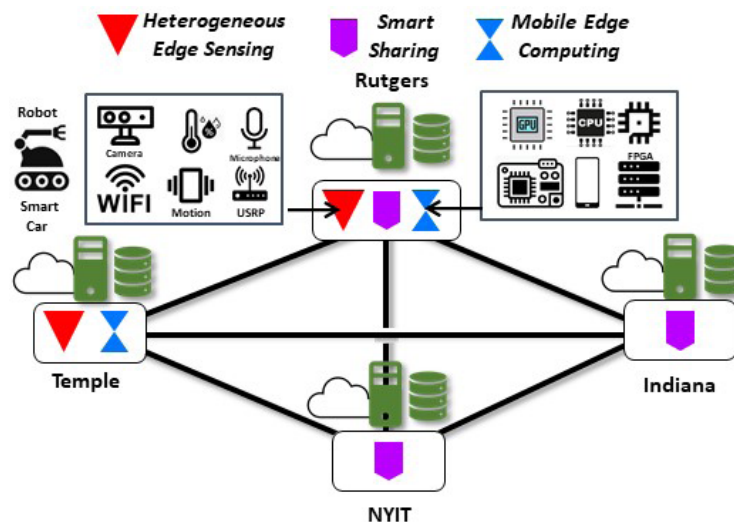

faculty news

Dario Pompili elevated to IEEE Fellow



It is our great pleasure announcing that the IEEE Board of Directors, at its November 2020 meeting, elevated Professor **Dario Pompili** to IEEE Fellow, effective January 1 2021, with the following citation: for contributions to underwater acoustic communication networks.

Each year, following a rigorous evaluation procedure, the IEEE Fellow Committee recommends a select group of recipients for elevation to IEEE Fellow. Less than 0.1% of voting members are selected annually for this member grade elevation.

Dr. Pompili's research focuses on the design, development, and implementation of novel sensing strategies to transform heterogeneous raw data into valuable information, by giving semantic meaning to the collected data, and then into knowledge through real-time, in-situ information fusion and integration. These strategies apply to those distributed systems that need to react in a timely manner to sensor information with an effective action such as cyber-physical systems, which feature a tight combination of, and coordination between, the system's computational and physical elements. His research also includes the study of throughput and delay performance limits of wireless networks, the development of computational methods and algorithms for optimal network control, and the design of distributed scalable algorithms with provable guarantees for applications using wireless heterogeneous networks.

Waheed Bajwa receives ARO Grant to Design Computationally Efficient Algorithms for Machine Learning



ECE Associate Professor **Waheed Bajwa** has been awarded a grant from the Army Research Office (ARO) for the project titled "Statistical learning for the modern datasets: Generalization bounds and near-optimal learning algorithms." The 3-year, \$360,000 award will advance the state-of-the-art in statistical learning theory and lead to computationally efficient algorithms for machine learning. While the statistical learning framework has long played a central role in advancing our understanding of machine learning systems, there is an interest in looking afresh at the questions of generalization error bounds, fundamental limits, and near-optimal

algorithms in the face of modern datasets that increasingly represent a 'zoo'. Indeed, the classical statistical learning works typically focused on centralized datasets that often had Euclidean geometry. In contrast, many of today's and tomorrow's applications of machine learning involve non-Euclidean datasets that are non-centralized, with data often streaming at very high rates, some of which might be compromised due to either gross errors or actions of adversarial entities. Such modern datasets necessitate development of fundamentally new analytical tools and algorithmic techniques for statistical learning-based study of machine learning systems. It is in this regard that this project leverages tools from stochastic approximation, (centralized and distributed) optimization theory, concentration-of-measure literature, information theory, robust statistics, and tensor algebra to derive generalization error bounds, fundamental limits on sample complexity, and near-optimal learning algorithms for machine learning from modern datasets. The outcomes of this project are expected to not only advance the state of the art in statistical learning theory, but also to lead to computationally efficient algorithms for machine learning that can be deployed in practical settings with the smallest number of training samples.

Shantenu Jha part of team that receives the ACM Gordon Bell Special Prize for High Performance Computing-Based COVID-19 Research

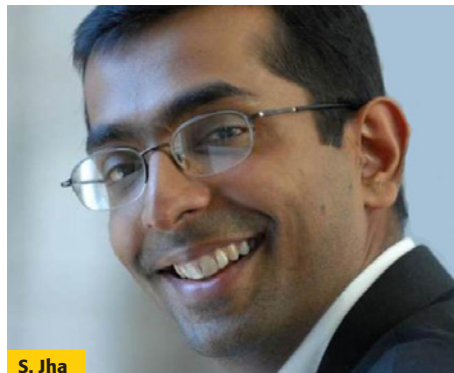

ECE Professor **Shantenu Jha** is part of a team that was recognized with the 2020 ACM Gordon Bell Special Prize for High Performance Computing-Based COVID-19 Research. This special prize was presented to a 12-member team for their project "*AI-Driven Multiscale Simulations Illuminate Mechanisms of SARS-CoV-2 Spike Dynamics*" and is being awarded in 2020 and 2021 to recognize outstanding research achievement toward the understanding of the COVID-19 pandemic through the use of high performance computing (HPC).

ECE Professor Receives DARPA Director's Fellowship Award



M. Wu

Chung-Tse (Michael) Wu, an assistant professor in the Department of Electrical and Computer Engineering, has received a prestigious Director's Fellowship Award from the Defense Advanced Research Projects Agency (DARPA). He was a recipient of a DARPA Young Faculty Award (YFA) in 2019.

The highly competitive DARPA Director's Fellowship Award provides an additional year of funding and support to a select group of DARPA Young Faculty Award recipients who have demonstrated exceptional technical achievement and leadership at the end of their initial two-year base award period.

"I am immensely grateful and truly humbled and honored that the research carried out by my team has been recognized by this highly prestigious award," says Wu. "It will enable us to continue working on cutting-edge research in developing wideband antenna arrays."

Wu's project, "Metamaterial Integrated Ultra-Broadband Antenna Array with Embedded Reconfigurable Non-Foster Circuits," seeks to develop an antenna relay with ultra-broad instantaneous bandwidth able to provide spectrum flexibility in communication and high resolution in radar sensing for military

applications. "The project can potentially have a profound impact on next-generation radar sensors and communication systems where a large instantaneous bandwidth is demanded," says Wu. The DARPA YFA program exposes leading junior faculty to Department of Defense, or DOD, national security challenges by providing them with funding, mentoring, and industry and DoD contacts to help them devise research projects that address the nation's security needs. Over time, the DARPA YFA program hopes to seed the next generation of STEM practitioners who will focus much of their careers on DoD and national security issues.

Michael Wu was the recipient of the National Science Foundation (NSF) Faculty Early Career Development (CAREER) Award in 2016 and the Defense Advanced Research Projects Agency (DARPA) Young Faculty Award (YFA) in 2019.

Rutgers Team receives NSF Grant for Enabling Spectrum Coexistence of 5G and Passive Weather Sensing



N. Mandayam

An interdisciplinary team of Rutgers researchers led by WINLAB Distinguished Professor **Narayan Mandayam** (PI) along with co-PIs **Chung-Tse Michael Wu** (Assistant Professor, ECE), **Ruo-Qian Wang** (Assistant Professor, CEE), and **Joseph Brodie** (Director of Atmospheric Sciences) are the recipients of an award from the National Science Foundation under the Spectrum and Wireless Innovation enabled by Future Technologies (SWIFT)

program for the project "Enabling Spectrum Coexistence of 5G mmWave and Passive Weather Sensing." This three-year project funded at \$750,000 addresses an emerging topic of increasing interest, namely the opening up of newer and higher spectrum for communication uses and the unintended effects on passive devices and legacy services not directly related to communications.

The project focuses on the utilization of newer spectrum in the mmWave bands that had not been previously allocated for commercial wireless applications, and studies the impact on collocated or adjacent spectrum utilized for other services, as well as strategies for mitigation of undesired impacts. Specifically, the 5G band allocated in the 26 GHz spectrum referred to as 3GPP band n258 has generated anxiety and concern in the meteorological data forecasting community including the National Oceanic and Atmospheric Administration (NOAA). This issue stems from 5G transmissions impacting the observations of passive sensors on weather satellites used to

detect the amount of water vapor in the atmosphere, which in turn affects weather forecasting and predictions. To this end, the proposed research project aims to tackle this issue by characterizing the impact of 5G transmissions on weather data measurements and prediction, and then develop cross-layer mitigation strategies including antennas/circuit (filtenna) design and direct modulation based beam steering that is integrated with cooperative medium access control, networking, and power control algorithms needed to enable coexistence between 5G services and weather prediction, as well as improved weather prediction algorithms. The team will investigate algorithm designs, reference architectures, and experiments on the COSMOS testbed that will provide pointers to engineering methodology for the design of spectrally and system power-efficient 5G and Beyond 5G (B5G) networks that can peacefully coexist with passive weather sensors. It will also enable the development of improved weather forecasting algorithms that are cognizant of the potential impact of unintended interference.

Wade Trappe receives NSF award under the Spectrum and Wireless Innovation enabled by Future Technologies (SWIFT) program



W. Trappe

ECE Professor **Wade Trappe** is the recipient of an award from the National Science Foundation under the Spectrum and Wireless Innovation enabled by Future Technologies (SWIFT) program for the project “Wideband Spectrum Coexistence Enabled by Photonic Circuits:

Cross-Layer Design and Implementation.” This is a three-year collaborative project with Rowan University and Princeton University funded at \$750,000 with Rutgers receiving \$170,000.

The focus of the proposed effort is to create a framework for spectrum coexistence that is beneficial for both active and passive users. Instead of simply switching to higher and undeveloped frequencies (which passive users of radio spectrum are often unable to do), the proposed research uses high frequency, optical signal carriers for interference separation, enabling the coexistence of active and passive users. The proposed coexistence solution will enable continuous availability of wideband spectrum for passive users, an important requirement for detecting unknown signals, since the bandwidth and the time window for

unknown astronomical, atmospheric, and geospace signals cannot be manipulated. Specifically, the effort will develop technologies that mitigate the interference observed by redesigning the transceiver hardware and exploring communication protocols at multiple layers. In the physical layer, the photonic system separates a mixed received signal in the congested radio spectrum by upconverting the signal carriers to optical frequencies, providing over 100GHz of bandwidth in a single channel. At the network level, communication protocols are redesigned to enable passive users to continuously access wideband spectrum and coexist with active users. The network layer protocol will optimize the deployment of the hardware system to minimize the cost of new infrastructures, better share spectrum, and improve communication throughput.

Anand Sarwate receives NIH Grant for Enabling Decentralized Analysis of Neuroimaging Data



A. Sarwate

ECE Associate Professor **Anand Sarwate** is the recipient of a new NIH award for the project entitled “COINSTAC 2.0: Decentralized, Scalable Analysis of Loosely Coupled Data” through the National Institute on Drug Abuse. This is a 5-year \$3 million grant to Georgia State University (**Vince Calhoun**, PI). The amount subcontracted to Rutgers is \$623,113.

In this project, Dr. Sarwate will work with Dr. Calhoun and researchers at the TRenDS Center to further develop the COINSTAC system for collaborative research, which provides an independent, open, no-strings-attached tool that performs analysis on datasets distributed across different locations. Thus, the step of actually aggregating data is avoided, while the strength of large-scale analyses can be retained. During this new phase they will respond to the need for advanced algorithms such as linear mixed effects models and deep learning, by proposing to develop decentralized models for these approaches and also implement a fully scalable cloud-based framework with enhanced security features. To achieve this, they will incorporate the necessary functionality to scale up analyses via the ability to work with either local or commercial private cloud environments, together with advanced visualization, quality control, and privacy and security features. This suite of new functions will open the floodgates for the use of COINSTAC by the larger

neuroscience community to enable new discovery and analysis of unprecedented amounts of brain imaging data located throughout the world. This will also improve usability, training materials, engage the community in contributing to the open source code base, and ultimately facilitate the use of COINSTAC’s tools for additional science and discovery in a broad range of applications. Next, they will extend the framework to handle powerful algorithms such as linear mixed effects models and deep learning, and to perform meta-learning for leveraging and updating fit models. And finally, they will test this new functionality through a partnership with the worldwide ENIGMA addiction group, which is currently not able to perform advanced machine learning analyses on data that cannot be centrally located. We will evaluate the impact of 6 main classes of substances of abuse (e.g., methamphetamines, cocaine, cannabis, nicotine, opiates, alcohol and their combinations) using the new developed functionality.

New Microchip Sensor Measures Stress Hormones from Drop of Blood

by John Cramer, *Rutgers Today*



M. Javanmard

ECE Associate Professor **Mehdi Javanmard** and his research group have published a paper on sensors for measuring stress hormones that was featured in the journal *Science Advances* (AAAS). The article titled “Single-step label-free nanowell immunoassay accurately quantifies serum stress hormones within minutes” is featured on the cover of the latest issue of AAAS.

A Rutgers-led team of researchers has developed a microchip that can measure stress hormones in real time from a drop of blood.

The study appears in the journal *Science Advances*.

Cortisol and other stress hormones regulate many aspects of our physical and mental health, including sleep quality. High levels of cortisol can result in poor sleep, which increases stress that can contribute to panic attacks, heart attacks, and other ailments.

Currently, measuring cortisol takes costly and cumbersome laboratory setups, so the Rutgers-led team looked for a way to monitor

its natural fluctuations in daily life and provide patients with feedback that allows them to receive the right treatment at the right time.

The researchers adopted the same technologies used to fabricate computer chips to build sensors thinner than a human hair that can detect biomolecules at low levels. They validated the miniaturized device’s performance on 65 blood samples from patients with rheumatoid arthritis. “The use of nanosensors allowed us to detect cortisol molecules directly without the need for any other molecules or particles to act as labels,” said lead author **Reza Mahmoodi**, a postdoctoral scholar in the Department of Electrical and Computer Engineering at Rutgers University-New Brunswick.

With technologies like the team’s new microchip, patients can monitor their hormone levels and better manage chronic inflammation, stress, and other conditions at a lower cost, said senior

author Mehdi Javanmard, an associate professor in Rutgers’ Department of Electrical and Computer Engineering.

“Our new sensor produces an accurate and reliable response that allows a continuous readout of cortisol levels for real-time analysis,” he added. “It has great potential to be adapted to non-invasive cortisol measurement in other fluids such as saliva and urine. The fact that molecular labels are not required eliminates the need for large bulky instruments like optical microscopes and plate readers, making the readout instrumentation something you can measure ultimately in a small pocket-sized box or even fit onto a wristband one day.”

The study included Rutgers co-author **Pengfei Xie**, a Ph.D. student, and researchers from the University of Minnesota and the University of Pennsylvania. The research was funded by the DARPA ElectRX program.



Safeguarding Tomorrow: Winning the Cybersecurity Arms Race

by Saman Zonouz



The following article was part of a Star-Ledger and NJ.com op-ed series on engineering fields that will change the world by Rutgers School of Engineering faculty.

Chances are, when you think of warfare, you think of soldiers in physical battles intended to kill people and destroy property. But today, we are threatened by a new kind of war. Cyber—or computer—warfare, which involves remote attacks and reconnaissance through nation-funded channels, is emerging—and being increasingly deployed—in place of more costly, conventional attacks.

At the same time, industry, government and university researchers have recognized the need for innovative approaches to thwart potentially devastating cyberattacks on everything from hospitals and voting machines to power grids and military systems. Headway has been made, for instance, by the U.S. Naval Academy's renewed insistence on teaching celestial navigation to limit undue reliance on GPS. While steps are being taken to overcome inherent cloud data and vulnerabilities in the Internet of Things (which encompasses everything connected to the Internet), there is increased pressure to establish cyberwarfare rules to mitigate future state-on-state cyber conflicts.

Attackers know that few things are more harmful to a society's economy, public health and safety than the disruption of

essential services provided by cyber-physical infrastructures such as power grids. And few things are more attractive targets for nation/state hackers and attackers than these infrastructures. The cost of a major power outage is astronomical: the massive 2003 Northeast electrical blackout affected 50 million people and cost an estimated \$6 billion. Beginning in 2015, we have seen the impact of repeated Russian cyberattacks on Ukraine's power grid, which disrupted the flow of electricity to consumers.

As the cybersecurity arms race between defenders and attackers escalates, researchers are asking: How can we protect vulnerable infrastructures from the disruption of cyberattacks?

While a number of purely cybersecurity protections have been developed in the past few decades for computing systems, these solutions are not directly applicable to cyber-physical systems such as power grids that seamlessly integrate computation and physical components to provide essential services.

Recognizing the vulnerability of our infrastructures to hackers and attackers, the U.S. government created programs such as the National Science Foundation's to cyber-physical systems program to fuel research in this field. The program has funded my ongoing research at the Rutgers School of Engineering in this area, which focuses on systems that have both cyber and physical components that interact to ensure that everything operates smoothly.

Many current cyber defense solutions are reactive; when an attack occurs, they react and adapt. We are, instead, developing proactive cyber defense solutions able to anticipate and respond effectively to cyberattacks. We also are designing secure mechanisms for cyber-physical critical infrastructures.

The first step in determining how best to protect electricity grids from cyberattacks is to pinpoint the weaknesses likely to be attacked. Manual tolerance procedures and cyber-security solutions alone offer inadequate protection. By identifying such weaknesses, effective safeguards can be designed, so that if an

attack happens, built-in defenses will exist.

While our solutions are inherently complicated due to the complex dynamics and interactions of cyber-physical systems, they are truly resilient. These systems' resilience does not guarantee absolute protection against any attack, yet it enables them to analyze, predict, tolerate, respond to – and recover from – highly debilitating cybersecurity attacks in near real time.

To date, we have successfully developed automated intrusion detection systems and automated response systems that we are transitioning to some industry partners to help them safeguard their own products.

This means that cyber-physical systems administrators and power grid operators will be able to both monitor incident response capabilities as well as to provide proactive response measures that will enable them to avoid future incidents—and ultimately protect some of our most vulnerable, yet essential, cyber-physical infrastructures.

Lasting solutions to pressing societal problems often result from productive research collaborations, which is why Rutgers researchers are also working together with Texas A&M University, the University of Illinois at Urbana-Champaign, Pacific Northwest National Labs and Sandia National Labs on a recently funded U.S. Department of Energy project to enhance the reliability and resilience of our energy infrastructure.

The project will revolutionize the way energy management systems are designed, deployed and operated by building a secure, next-generation, end-to-end energy management system that is both cyber-physical and secure. By being able to detect malicious and abnormal events by fusing cyber and physical data—and facilitating online and automated control actions – these energy management systems will further safeguard cyber-physical critical infrastructures.

Saman Zonouz is an associate professor in the Department of Electrical and Computer Engineering at Rutgers University School of Engineering.

ECE Researchers win Best Paper Award at the 2021 IEEE/IFIP Wireless On-demand Network systems and Services Conference (WONS)

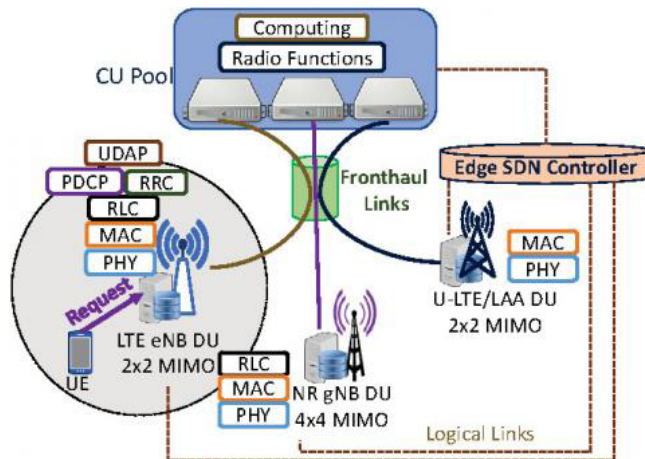

Associate Professor **Dario Pompili** and ECE graduate students **Ayman Younis** and **Brian Qi** have won the Best Paper Award at the 2021 IEEE/IFIP Wireless On-demand Network systems and Services Conference (WONS), which was held remotely on 9-11th March 2021, for their paper titled “QLRan: Latency-Quality Tradeoffs and Task Offloading in Multi-node Next Generation RANs”.

Wireless on-demand network systems and services have become pivotal in shaping our future networked world. Starting as a niche application over Wi-Fi, they can now be found in mainstream technologies like Bluetooth LE, LTE Direct and Wireless LANs, and have become the cornerstone of upcoming networking paradigms including mesh and sensor networks, cloud networks, vehicular networks, disruption tolerant and opportunistic networks, and in-body networks. The challenges of this exciting research field are numerous. Examples include how to make smart use of these novel technologies when multiple technologies or a mix of permanent services and on-demand networking opportunities are available to a network node, how to provide robust services in highly dynamic environments, how to efficiently employ and operate heavily resource-constrained devices, and how to develop robust and lightweight algorithms for self-organization and adaptation. WONS, now in its 16th edition, is a high-quality forum to address these challenges. The winners were presented with an award certificate and a USD 600 prize.

Next-Generation Radio Access Network (NG-RAN) is an emerging paradigm that provides flexible distribution of cloud computing and radio capabilities at the edge of the wireless Radio Access Points (RAPs). Computation at the edge bridges the gap for roaming end users, enabling access to rich services and applications. In this paper, we propose a multi-edge node task offloading system, i.e., QLRan, a novel optimization solution for latency and quality tradeoff task allocation in NG-RANs. Considering constraints on service latency, quality loss, and edge capacity, the problem of joint task offloading, latency, and Quality Loss of Result (QLR) is formulated in order to minimize the User Equipment (UEs) task offloading utility, which is measured by a weighted sum of reductions in task completion time and QLR cost. The QLRan optimization problem is proved as a Mixed Integer Nonlinear Program (MINLP) problem, which is a NP-hard problem. To efficiently solve the QLRan optimization problem, we utilize Linear Programming (LP)-based approach that can be later solved by using convex optimization techniques. Additionally, a programmable NG-RAN testbed is presented where the Central Unit (CU), Distributed Unit (DU), and UE are virtualized using the OpenAirInterface (OAI) software platform to characterize the performance in terms of data input, memory usage, and average processing time with respect to QLR levels. Simulation results show that our algorithm significantly improves the network latency over different configurations.

Hana Godrich voted 2020-21 EGC Professor of the Year in ECE



H. Godrich

ECE Associate Professor **Hana Godrich** has been voted by the Rutgers SOE Undergraduate Student Body to receive the 2020-21 **Engineering Governing Council (EGC) Professor of the Year Award** from within the Department of ECE. This award is annually given to one faculty member from each department in Rutgers SOE who best exemplifies the SOE mission of “Education, Research, and Service.” Dr. Godrich has been an outstanding teacher in ECE and also coordinates the successful Capstone Design program. She has previously been recognized with the prestigious **Presidential Award for Excellence in Teaching** for the year 2016-17.

The ECE Department announces Faculty Retirements

The Department of Electrical and Computer Engineering salutes the dedication and contributions of four ECE faculty who recently retired.

- **Grigore Burdea**
- **Richard Mammone**
- **Sigrid McAfee**
- **Jian Zhao**

We thank them for their long service and commitment to teaching and research.

Voice Attacks on Voice Assistant Systems

by Yingying Chen

Rutgers ECE researchers are studying the vulnerabilities of Voice Assistant (VA) systems, such as Google Assistant and Amazon Alexa, which are widely deployed on various smart and IoT devices and bring unprecedented convenience to our daily life. These systems have been integrated into smart-phones (e.g., Apple Siri), smart speakers (e.g., Amazon Alexa, Google Home), smart home appliances (e.g., smart TVs), and even vehicles (e.g., Tesla Voice Commands). With the increasingly prevalent usage of VA systems, a user can unlock the doors of a car, make mobile payments, and schedule personal appointments with a simple voice command. Powered by advanced machine learning techniques, VA systems have achieved near-human performance in both understanding the user's speech and identifying the user's identity. Such performance advancements enable a broad range of voice-controlled functionalities, such as unlocking personal devices, inquiring personal schedules, and controlling home appliances. However, the ever-growing deployment of VA systems also raises public concerns about their inherent vulnerabilities. Imperceptible noises, called adversarial perturbations, can be added to the speech input to deceive the machine learning models.

In collaboration with the University of Tennessee at Knoxville, Rutgers ECE Professors **Yingying Chen** and **Bo Yuan** are exploring such security vulnerabilities of VA systems. Existing audio adversarial attacks require prior knowledge on the speech input to generate the adversarial perturbations, and thus they cannot be applied to streaming input (e.g., live human speech), which are more commonly used to access VA systems. In addition, to launch effective attacks, the adversarial perturbations usually need to be strictly synchronized with the streaming input, which is difficult to achieve in practice. To overcome these two challenges, the Rutgers ECE team developed a systematic approach to generate adversarial perturbations that can be applied to streaming speech input in a synchronization-free manner. To remove the requirement on prior knowledge, the team proposes to train on a set of speech samples, instead of individual speech, to generate input-agnostic adversarial perturbations, which can be added to arbitrary speech input to spoof the VA system. Furthermore, the team designs sub-second adversarial perturbations that are optimized under random time delays, enabling the perturbation effective when being added to the streaming speech input with

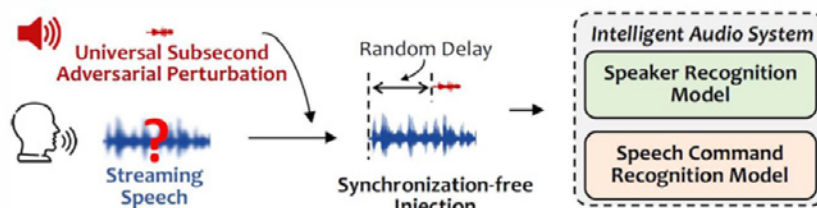

HVAC vs. traditional hidden voice commands in the presence of a defense classifier.

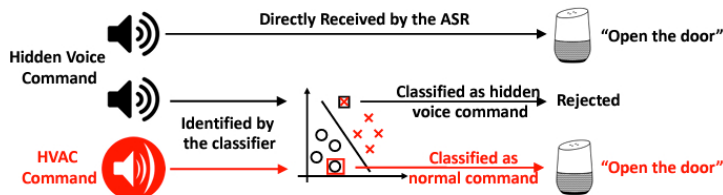

HVAC commands vs. hidden voice commands in the presence of a defense classifier.

a synchronization-free manner. Outcomes of this project were published in the ACM Conference on Computer and Communications Security (CCS'20), a premier conference in computer security, with the paper titled "AdvPulse: Universal, Synchronization-free, and Targeted Audio Adversarial Attacks via Subsecond Perturbations". The research work makes the public aware of the security vulnerabilities of using voice assistant systems and gains the attention of the manufacturers and service companies (e.g., Google, Amazon, Apple).

Furthermore, in collaboration with with Texas A&M University and University of Tennessee at Knoxville, Professor Chen is exploring security threats brought by hidden voice command attacks. Despite the great convenience of using voice commands, the Deep Neural Networks (DNNs) serving as the computation cores of VA systems have been proved to be fragile against hidden voice command attacks. An adversary can use noise-like obfuscated voice commands, Comments restricted to single page which are unintelligible to human beings but can be interpreted as normal commands by DNNs. Compared with audio adversarial attacks, hidden voice command attacks are easier to launch and are more effective in practice. The obfuscated voice commands are less

sensitive to the acoustic distortions during audio playback and propagation, and thus can be stealthily embedded in a broadcast or a trending YouTube video to attack a large number of mobile and IoT devices. Hidden voice attacks introduce a severe threat against VA systems. Existing studies have demonstrated that they can be detected and defended using a machine learning classifier. The hidden voice commands sound like noises, and exhibit significantly different acoustic characteristics compared with live human speech. Thus, the VA systems can incorporate a machine learning classifier to determine thereceived speech as being issued by a human or machine generated. Prof. Chen's research team finds that by elaborately mixing the audio signals of hidden voice command and normal human voice command, the acoustic characteristics can lead to false predictions of the defense classifier. To ensure the hybrid hidden voice command unintelligible to human ears, the speed and pitch of the hybrid voice command are tuned and distorted. This work has been published in ACM ASIA Conference on Computer and Communications Security (ASIACCS'21) with the paper title "HVAC: Evading Classifier-based Defenses in Hidden Voice Attacks". This work further shows the security vulnerabilities of VA systems even under the machine learning classifier-based defender.

Inspired by Star Trek: A Technology-Driven Approach to Personalized Medicine

By Umer Hassan



U. Hassan

The following article was part of a Star-Ledger and NJ.com op-ed series on engineering fields that will change the world by Rutgers School of Engineering faculty.

Real world innovations—from submarines to self-driving cars—come straight from imaginary worlds of science fiction. Think Star Trek’s handheld tricorder, a medical diagnostic device that made its first appearance in the original TV series. This sci-fi precursor is now changing the face of personalized medicine by taking the tricorder concept to the next level.

Today, diabetics can anticipate a biosensor able to monitor their glucose levels through perspiration. An electrical graphene biosensor implant could detect genetic mutations as they happen, while UK researchers are developing a wearable biosensor that will collect data and assess the efficacy of rehab equipment and exercise.

Other biosensors will be able to quickly and inexpensively detect costly and potentially fatal medical conditions such as sepsis and AIDS. Together with Rutgers University colleagues, clinical and industry partners, my lab has been working to solve these global health challenges with new tools that focus on a highly personalized approach to medicine. Since the COVID-19 pandemic began, we are also hoping to apply this technology to fight against the coronavirus. Sepsis—the body’s life-threatening response to infection—is not only deadly, it is the most expensive inpatient

medical condition in the United States, with patients who develop sepsis often spending days in intensive care units at a cost of \$10,000 a day—or more. Recognizing that sepsis is responsible for as many as six million largely preventable deaths a year, the World Health Organization has identified the prevention, diagnosis, and management of sepsis as a pressing global health priority.

By applying electrical and computer engineering skills to identify new biomarkers and devise machine-learning algorithms, or artificial intelligence systems, we hope to dramatically improve clinicians’ abilities to diagnose, predict—and ultimately manage—sepsis. Simply reacting to diseases is no longer enough—we need to predict them in order to treat patients in a much smarter way.

To this end, we are building an inexpensive medical device that even minimally trained health care providers can use to accurately diagnose sepsis. This automated device would cost less than \$10 a test and be simple to operate not only in resource-limited settings, but anywhere where a rapidly confirmed diagnosis of sepsis is needed.

In sub-Saharan Africa, where only one person in eight is even tested for HIV, many people infected with HIV go undetected until they develop severe complications from the disease. Those who are tested should be tested much earlier to receive access to therapeutics for their personalized care.

A related area of development includes cheap, disposable biosensors that will be as easy and convenient to use as a home pregnancy strip test to detect infections with people living with HIV/AIDS in underdeveloped sub-Saharan African nations. A secondary goal is to develop sensors able to monitor a patient’s response to the antiretroviral therapy they receive.

The positive health and economic impact of such sensors would be felt not only in underdeveloped nations, but also in the United States by reducing the cost of a single HIV test from hundreds of dollars to as little as \$10. My lab has also made the fight against COVID-19 an urgent research priority and a

natural extension of our existing work. We are seeking to develop a sensor that could measure the ability of white blood cells to kill the virus in high-risk human patients. This could lead to new therapeutic interventions, and could help develop a rapid, easy-to-use widespread stratification test.

In terms of predicting health outcomes and personalizing therapeutic approaches economically, we are also collaborating with Robert Wood Johnson Medical Hospital to do just that by combining sensor data and electronic medical records data.

Advancing personalized medicine and health monitoring is also a key concern of my Rutgers School of Engineering colleague, electrical and computer engineering associate professor **Mehdi Javanmard**. His lab has been developing a “lab on a chip” with the potential to monitor everything from health to germs to pollutants. His team’s innovative biosensor could be used in hand-held devices—akin to that old Star Trek tricorder—or wearable devices that measure biomarkers to track your health and exposure to harmful bacteria, viruses, and pollutants.

While a single biomarker is measured in home pregnancy tests, multiple biomarkers need to be tracked simultaneously to diagnose and manage complex health conditions such as heart disease, cancer, and inflammatory diseases. The lab on a chip is designed to meet that challenge. Additionally, within the next three to five years, a lab on a chip could quickly analyze a sample of what—if any—harmful bacteria are on a doorknob of a bathroom; test a salad for the presence of E. coli or Salmonella bacteria; or even quickly test for the flu.

In time, a future version of the smartphone will be the true tricorder of tomorrow. Smartphone based health sensors will ultimately transform the smartphone into an intelligent, all-in-one monitoring and diagnostic device.

Umer Hassan, an assistant professor of electrical and computer engineering at Rutgers University School of Engineering, holds a joint appointment at Rutgers Global Health Institute.

Dario Pompili receives NSF Grant for Advancing Cloud based Radio Access and Spectrum Sharing



D. Pompili

ECE Associate Professor **Dario Pompili** is the recipient of a new NSF award for the project titled “xl_NGRAN–Navigating Spectral Utilization, LTE/WiFi Coexistence, and Cost Tradeoffs in Next Gen Radio Access Networks through Cross-Layer Design.” This is a 3-year \$450K grant from the Spectrum and Wireless Innovation enabled by Future Technologies (SWIFT) program.

In this project, Dr. Pompili and his team will design the xl_NGRAN framework for 5G (virtualized) cellular networks that enables optimized cross-layer decisions for on-demand resource allocation and in-network content caching, and navigates the tradeoffs among radio resources, system cost, LTE/WiFi technology coexistence, and caching service. The rapid growth of mobile multimedia applications and the Internet of Things (IoT) have placed severe demands on wireless network infrastructures such as ultra-low latency, user experience continuity, and high reliability. Mobile devices are nowadays the predominant medium of access to Internet services due to an increase in their computation and communication capabilities. However, enabling applications that require real-time, in-the-field data collection and processing using mobile devices is still challenging due to (1) the insufficient computing capabilities and unavailability of aggregated/global data on individual mobile devices and (2) the communication cost and response time involved in offloading data to

remote computing resources for centralized computation. In light of these limitations, the Mobile Edge Computing (MEC) concept has emerged, which aims at uniting telco, IT, and cloud computing to deliver cloud services directly from the network edge. With a cloud-based framework, and specifically via NG-RAN virtualization, network resources including physical infrastructure and spectrum are abstracted in such a way as to provide a developing platform to support various services, thus maximizing resource utilization. The framework performance will be assessed via three research tasks and one validation/assessment plan considering Augmented Reality (AR)-based applications in a smart-device context. In Task 1, resource-allocation solutions will be designed, while considering

LTE/WiFi coexistence requirements, to minimize the power consumption at both the cell sites and the Central Unit (CU) pool by dynamically adapting the Distributed Unit (DU) density and size of the Virtual Machines (VMs) hosting the DU pool based on traffic fluctuations. In Task 2, functional splitting will be enabled through cross-layer design; a novel dynamic radio-resource allocation and flexible functional split will be introduced to optimize the accumulated data rate and network power consumption in NG-RANs. In Task 3, the joint problem of service caching and task-offloading assignment will be studied in a dense network where each user can exploit the degrees of freedom in offloading different portions of its computation task to nearby DUs.

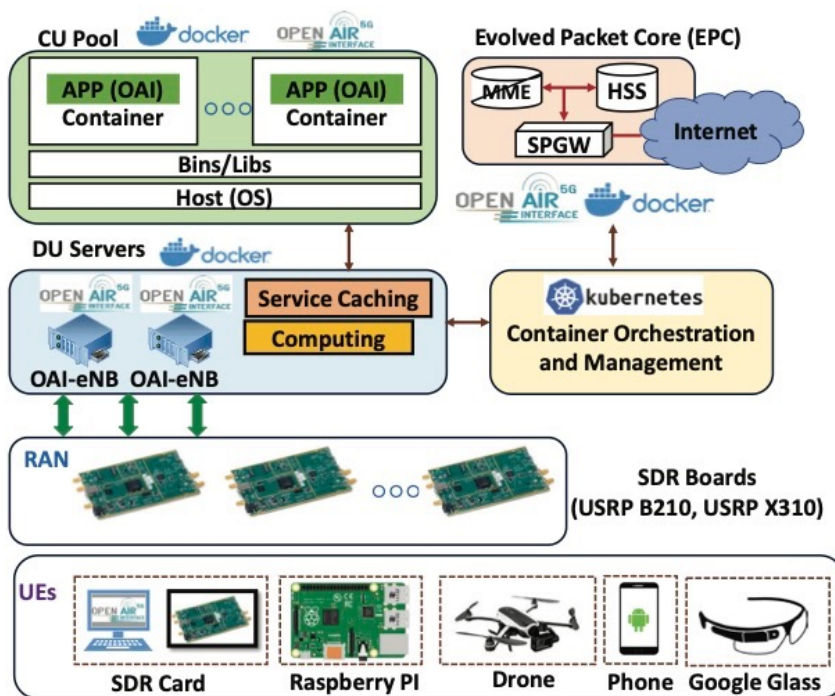

Proposed cellular network testbed leveraging virtualization technology to study spectral utilization, LTE/WiFi coexistence, and cost tradeoffs in Next Generation Radio Access Networks.

Dionysios Kalogierias joined Yale University as a tenure-track assistant professor of Electrical Engineering in July 2021



D. Kalogierias

Born in Zakynthos, Greece, in 1986, and after getting an MEng and an MSc from the University of Patras, Greece, in 2010 and 2012, respectively, **Dionysios Kalogierias** came to the US in 2012 to pursue a PhD at Rutgers ECE under the guidance of Prof. **Athina Petropulu**. During five wonderful PhD years at Rutgers ECE, he published extensively on core topics in statistical estimation, stochastic optimization and wireless communications, and he received several awards for his work, including both the 2017 Rutgers ECE Graduate Program Academic Achievement Award and the 2017 Rutgers SOE Outstanding Graduate Student Award, as well as the Best Student Paper of the Special Sessions Award at IEEE ICASSP

2016. After his graduation in June 2017, Dionysios joined the Department of Operations Research and Financial Engineering (ORFE) at Princeton University as a postdoctoral research associate, where he worked on the development of computationally efficient algorithms for risk-aware optimization and learning, and also large-scale supply scale management and simulation. In June 2019, he joined the Department of Electrical and Systems Engineering at the University of Pennsylvania as postdoctoral researcher, where he worked on reinforcement learning, machine learning for wireless communications, wireless autonomy, and also risk-aware optimization for Bayesian estimation and control for which he also received the Best Student Paper Award at IEEE ICASSP 2020.

Since July 2021, and after spending one year as a tenure-track assistant professor at the Department of ECE, Michigan State University, Dionysios has been with the Department of EE, Yale University. His research blends elements of a diverse research experience, and focuses on enabling trustworthy and robust wireless autonomy by leveraging and developing tools spanning the areas of machine and reinforcement learning, optimization and control, signal processing, and statistical risk management.

Alumnus Ed Chao Delivers Convocation Remarks



T. Chao

Edward T. Chao ENG'92 is a globally recognized entrepreneur who over the course of his 30-year in the wireless communications industry has brought disruptive technologies to the market that form the mobile Internet. He is currently CEO of Polte, a 5G positioning tech company recognized as a top Internet of Things (IoT) startup, where he led the company from a couple of engineers in a borrowed conference room to a leading provider of technologies that power IoT solutions globally.

Previously, Chao was an executive at metroPCS where he established the company as a leader in bringing affordable wireless services to the masses. He also held leadership positions at Lucent Technologies-Bell Labs and Nortel Networks, where he helped drive the transformation of cellular communications from fuzzy analog phone calls to what we now know as 4G and 5G. Chao served at the White House as a member of the U.S. Digital Service, an elite technology unit that helps deliver better government services to the American people through technology and design.

Chao earned his bachelor's degree in electrical and computer engineering from Rutgers University in 1992. He resides in Dallas with his family and enjoys coming back to New Jersey to visit family, friends, and old colleagues, and to eat at diners.

thank you

The ECE Department Wishes to Thank All the Donors Who Supported Us During the Past Year.

Your Contributions Helped Us

- Attract brilliant new faculty, by supplementing startup packages
- Attract excellent students, by providing fellowships
- Support student travel to conferences
- Maintain state-of-art laboratories for educating our students on cutting edge technology
- Create materials to advertise our program to the external world.

Your support has been essential in our ability to sustain excellence.

To support ECE please visit
www.ece.rutgers.edu/donate
or scan the code below



industry advisory board

The **Advisory Board** provides input on academics, research, administration, outreach, advocacy, and development. The Board reviews the graduate and undergraduate curriculum and degree programs, program educational objectives, and program outcomes, and offers suggestions for change to keep them current. The Board evaluates the quality and scope of our research, its relationship to our programs, its relevancy and helps guide future directions. The Board recommends ways to build new relationships with industry and to strengthen those we have.

Don Bachman
Head of Strategy
Russelectric,
A Siemens Business



Gihan B. Oraby
Deputy Director for the Weapons
and Software Engineering Center (WSEC)
Picatinny Arsenal, U. S. Army



Dorin Comaniciu
Vice President
Medical Imaging Technologies
Siemens Healthcare



Bharat Parikh
President
AASKI Technology Business Unit
MAG Aerospace



Ed Cordero
Associate Director
Protiviti



Pete Pupalais
Founding Partner and Director
of Signal Integrity
Nubis Communications



Anindo Dutta
Partner
Ernst & Young, Asia Pacific



Joe Rambala
President
Electronic Warfare,
Space & Airborne Systems
L3Harris



David Famolari
Managing Director
Hearst Ventures



Thomas Richardson
Vice President
Engineering
Qualcomm Inc.



Kfir L. Godrich
Managing Director
BlackRock



Ashwin Sampath
Senior Director of Technology
Qualcomm Inc.



Rajiv Jain
CTO for Financial Services Industry
CDW



Sanyogita Shamsunder
Director of Strategy-Technology
Network CTO Office
Verizon Wireless



Ed Knapp
Chief Technical Officer
American Tower Corporation



Stephen Wilkus
Chief Technology Officer
Spectrum Financial Partners



Chris Marty
Managing Director
Two Sigma Investments LP



Rita Marty
Vice President
AT&T - Chief Security Office



RUTGERS
School of Engineering



RUTGERS

Department of Electrical and Computer Engineering
Rutgers, The State University of New Jersey
94 Brett Road
Piscataway, NJ 08854

Non Profit org
US POSTAGE PAID
New Brunswick, NJ 08901
Permit 157

RUTGERS
School of Engineering